Bathy 2010™ CHIRP Sub Bottom Profiler and Bathymetric Echo Sounder

- Installation
- Operation
- Maintenance

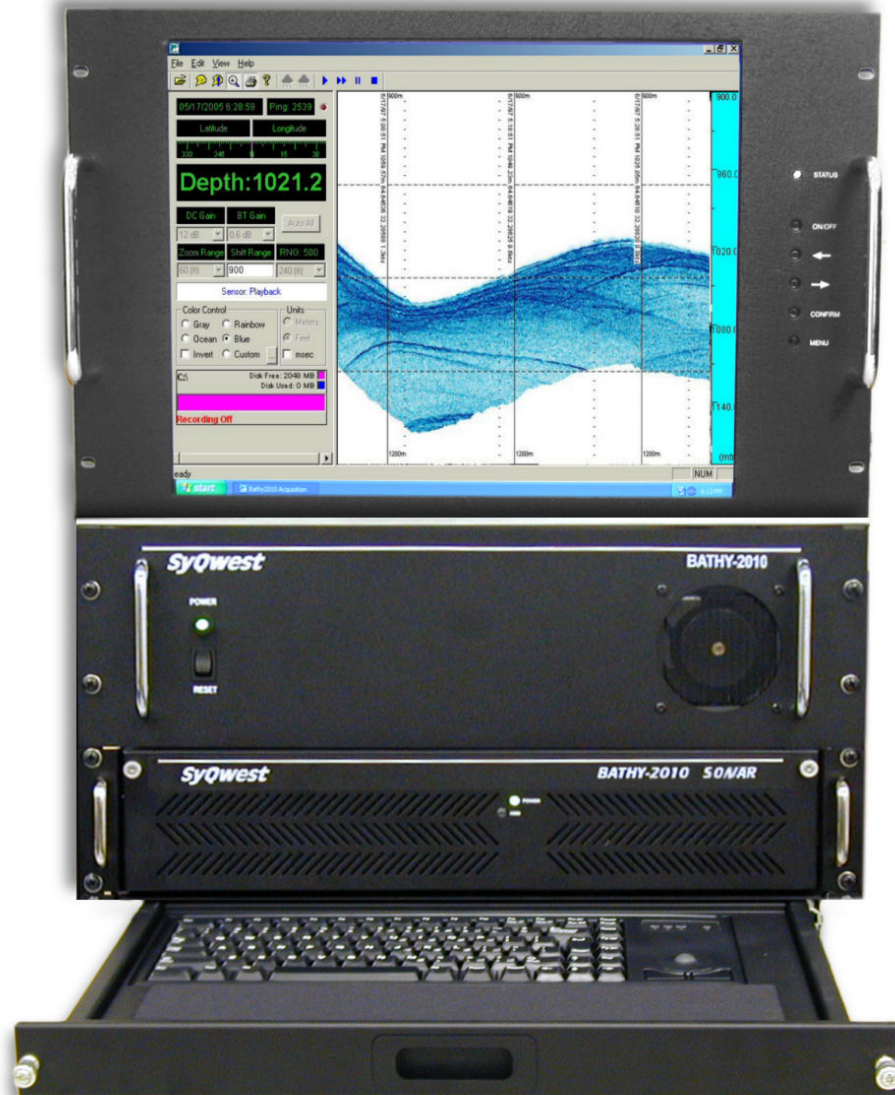

TABLE OF CONTENTS

1.0 Introduction	1-1
1.1 Safety	1-1
1.2 List of Additional Items	1-2
1.3 Shipping and Handling	1-2
1.4 Emergency Operation and Shutdown	1-2
2.0 System Overview	2-1
2.1 Bathy 2010 Data Acquisition and Playback Unit	2-1
2.2 LPT (Linear Power Transmitter)	2-2
2.3 Hardcopy	2-2
2.4 TR-109 (3.5KHz Transducer).....	2-3
2.4 TC-12/34 (12KHz Widebeam Transducer	2-3
2.5 TC-12NB (12KHz Narrowbeam Transducer)	2-3
2.6 TC-2084 (33KHz Transducer).....	2-3
2.7 System Power Up and Controls (Power switches and Keyboard)	2-3
2.8 System Indicators	2-3
3.0 BATHY-2010 SOFTWARE INSTALLATION AND OPERATION	3-1
3.1 Installing The Software.....	3-1
3.2 Setting Up The Bathy-2010 Ethernet Interface.....	3-2
3.2.1 Setting a Static IP Address for Network Connection.....	3-2
3.2.2 Setting an Alternate Static IP Address for Network Connection	3-3
3.3 Bathy 2010 P Software Operation	3-4
3.3.1 - The Main Window.....	3-4
3.3.2 – MENU BAR	3-12
3.3.2.1 Edit Menu	3-14
3.3.2.2 View Menu	3-20
3.3.2.3 Help Menu	3-22
3.3.2.4 SEG-Y File Storage Format.....	3-22
3.3.2.5 Navigation input	3-23
3.4 Heave Data	3-26
3.5 Digitized Depth.....	3-26
3.6 External Synchronization.....	3-26
4.0 (Data Logger) Serial Input/Output Protocol	4-1
5.0 Equipment Specifications.....	5-1
5.1 Specifications.....	5-1
5.1.1 Bathy 2010 Specifications	5-1
5.2 LPT 2 Specifications (Refer to Figure 5-2)	5-3
6.0 Theory of Operation	6-1
6.1 Hydrographic Data Processing	6-1
6.2 Pinger Mode Theory of Operation.....	6-3
7.0 Installation	7-1
7.1 System Setup	7-1
7.2 Environment	7-2
7.3 Input Power.....	7-2
7.4 Linear Power Transmitter	7-2
7.5 Transducers.....	7-2
7.6 Hardcopy Installation.....	7-3
7.6.1 TDU-850.....	7-3
7.7 Serial Interfaces	7-3
7.8 Keyboard / Trackball.....	7-4

**Operations
and
Maintenance Manual**

7.9 External Sync..... 7-4

8.0 MAINTENANCE..... 8-1

8.1 POST (Power On Self Test) 8-1

8.2 Firmware Update 8-1

8.3 Firmware Update Connection..... 8-2

8.4 Firmware Update Process 8-2

8.5 Transducer Impedance Test..... 8-3

9.0 General Information..... 9-1

9.1 Selecting a Location for the Transducer 9-1

9.2 Handling Transducers..... 9-2

9.3 Portable Transducer Installation 9-2

9.3.1 Portable Transducer Maintenance..... 9-5

9.4 Permanent Transducer Installation 9-5

9.5 Seachest Transducer Installation 9-5

10.0 APPENDIX A Drawings and Parts Lists (BATHY 2010 SERVER Unit)..... 10-1

11.0 APPENDIX B Drawings and Parts Lists (BATHY 2010 SONAR Unit)..... 11-1

12.0 APPENDIX C Drawings and Parts Lists (LPT Unit)..... 12-1

TABLE OF FIGURES

Figure 2-1 BATHY-2010 CONTROLS AND SYSYEM INDICATORS..... 2-4

Figure 3-1 Main Window..... 3-4

Figure 3-2 Zoom Mode..... 3-5

Figure 5-1 Bathy 2010 DESIGN ARCHITECTURE 5-2

Figure 5-2 LPT MODULAR DESIGN ARCHITECTURE 5-4

Figure 7-1 BATHY-2010 TOP LEVEL INSTALLATION DIAGRAM P/N P05300-24 REV A 7-5

Figure 7-2 BATHY-2010 SUB-BOTTOM SYSTEM TOP LEVEL PARTS LIST P/N P05500-22..... 7-6

Figure 7-3 LPT-5/10 POWER CABLE P/N C00047-2 7-7

Figure 7-4 LPT I/O INTERFACE CABLE P/N C00043-1 7-7

Figure 7-5 TRANSDUCER WIRING, TYPICAL / ALTERNATE..... 7-7

Figure 7-6 B2010 / LPT RECEIVER CABLE P/N C00177-1 7-8

Figure 7-7 POWER STRIP CABLE P/N C00063-1..... 7-8

Figure 7-8 EXT SYNC / KEYPULSE WIRING..... 7-9

Figure 7-9 CABLE KIT (TR-109) (optional, special order) P/N 909955-015 7-9

Figure 7-10 TR-109 TRANSDUCER P/N 973690-1 7-10

Figure 7-11 TR-109 TRANSDUCER ARRAY INSTALLATION P/N 869159..... 7-11

Figure 7-12 TC-12/34 TRANSDUCER P/N 1052994 7-12

Figure 7-13 TC-12NB TRANSDUCER P/N P00363-1 7-13

Figure 7-14 JUNCTION BOX ASSEMBLY P/N P00778-x (ref only)..... 7-14

Figure 7-15 4 TR-109 TRANSDUCER ARRAY SCHEMATIC P/N 909153-1 7-15

Figure 7-16 4 / 8 TR-109 TRANSDUCER ARRAY SCHEMATIC P/N P03308-1 7-15

Figure 7-17 12 TR-109 TRANSDUCER 3x4 ARRAY SCHEMATIC P/N 909196-1 7-16

Figure 7-18 12 TR-109 TRANSDUCER 4x3 ARRAY SCHEMATIC P/N 909196-2 7-17

Figure 7-19 16 TR-109 TRANSDUCER ARRAY SCHEMATIC P/N 909190-1 7-18

Figure 7-20 SEA CHEST ASSEMBLY P/N P01511 (reference only) 7-19

Figure 7-21 RACK OUTLINE AND ASSEMBLY P/N P05334-X (*Optional*) 7-20

Figure 8-1 TRANSDUCER IMPEDANCE TEST DIAGRAM..... 8-3

Figure 9-1 Typical Over the Side Mount (reference drawing) 9-3

Figure 9-2 Over The Side Transducer Mounting Picture 9-4

Figure 10-1 SERIAL I/O PCB..... 10-1

Figure 11-1 Sonar Unit Front Panel Indicators and Controls 11-1

Figure 11-2 Sonar Unit Rear Panel Connections.....	11-1
Figure 11-3 B2010 INTERFACE PCB	11-2
Sonar Unit Wiring Figure 11-4.....	11-3
Figure 9-5 TRANSCIVER PCB	11-5
Figure 9-6 DIGITAL DSP PCB	11-6
Figure 12-1 LPT-10 AMPLIFIER	12-2
Figure 12-2 LPT-5/10P LEVEL ASSEMBLY P/N A00057-X, A00171-X.....	12-3
Figure 12-5 LPT-2/5P UNIT WIRING DIAGRAM P/N S00183-X.....	12-8
Figure 12-6 LPT-5/10 Weight & Dimensions P/N A00171 or A00157-X.....	12-9
Figure 10-7 LPT-2/5P Weight & Dimensions P/N A00183-X.....	12-9
Figure 12-3 LPT-2 TOP LEVEL ASSEMBLY P/N A00183-X.....	12-10
Figure 12-8 LOSS OF PHASE DETECTOR PCB P/N A00046-2.....	12-13
Figure 12-9 VOLTAGE & CURRENT MONITOR PCB P/N A00048-x.....	12-14
Figure 12-10 CURRENT SENSE PCB P/N A00070-1.....	12-15
Figure 12-11 LPA- MODULE ASSEMBLY AND PARTS LIST	12-16
Figure 12-12 MODULATOR PCB P/N A00044-2	12-17
Figure 12-13 POWER BRIDGE PCB P/N A00114-1	12-18

TABLE OF TABLES

Table 7-1 P/N P05306-x BATHY-2010 ACCESSORY KIT.....	7-3
Table 9-1 Portable Transducer Installation Parts.....	9-3
Table 10-1 BASIC LPT-5 / 10 RECOMMENDED SPARES LIST.....	12-1

THIS PAGE INTENTIONALLY LEFT BLANK

1.0 Introduction

The BATHY-2010 system provides high performance bathymetric and sub-bottom survey capability from shallow inland waterways to full ocean depth. The system configuration is extremely flexible and can be easily modified to accommodate the specific needs of individual customers. The BATHY-2010 system is comprised of the following electronic components: (Refer to Figure 7-1)

- Bathy 2010 Data Acquisition System (Sonar Unit)
- Bathy 2010 Server
- LPT 5-30KW Linear Power Transmitter
- Bathy 2010 LCD Display
- Bathy 2010 Rackmount Keyboard/Trackball
- Hardcopy Support for a multitude of standard devices
and one or more of the following transducers:
 - TR-109 3.5KHz Transducer
 - TC-12/34 12KHz Widebeam Transducer
 - TC-12NB 12KHz Narrowbeam Transducer
 - TC-2084 33KHz Transducer

An individual configuration may contain all or a subset of the above mentioned components.

1.1 Safety

The following are general safety precautions that are not related to any specific procedures and therefore do not appear elsewhere in this publication. These are recommended precautions that personnel must understand and apply during many phases of operation and maintenance.

KEEP AWAY FROM LIVE CIRCUITS - Operating personnel must at all times observe all safety regulations. Do not replace components or make adjustments inside the equipment with the high voltage supply turned on. Under certain conditions, dangerous potentials may exist when the power control is in the off position, due to charges retained by capacitors. To avoid casualties, always remove power and discharge and ground a circuit before touching it.

DO NOT SERVICE OR ADJUST ALONE - Under no circumstances should any person reach into to enter the enclosure for the purposes of servicing or adjusting the equipment except in the presence of someone who is capable of rendering aid.

RESUSCITATION - Personnel working with or near high voltages should be familiar with modern methods of resuscitation.

The following **WARNINGS** appear in the text of this manual and are repeated here for emphasis:



-WARNING-

120VAC is present in the Bathy 2010 Unit and Server. Thus, the risk of electrical shock and serious injury is present. All precautions should be taken to insure no human contact is made to the unit while power is on.



-WARNING-

240VAC, 120VAC and 300VDC are all present in the LPT Unit. They are only accessible after the safety shield is removed. Thus, the risk of electrical shock and serious injury is present. All precautions should be taken to insure no human contact is made to the unit while power is on.

The following CAUTIONS appear in the text of this manual and are repeated here for emphasis:



-CAUTION-

This test involves contact with ESD (Electrostatic Sensitive Devices). Normal precautions involve the use of anti-static protection material and ground straps for test personnel.

1.2 List of Additional Items

There are no additional items required to operate the BATHY-2010 system.

1.3 Shipping and Handling

The BATHY-2010 units are delivered in reinforced cardboard with packing foam inside. The boxes and foam should be saved for future use. If saving the box and foam is not practical, equivalent packaging procedure should be used.

1.4 Emergency Operation and Shutdown

Under any emergency, adverse, or abnormal ship conditions, the BATHY-2010 system electronics should be powered down. The system is powered down by placing the toggle switch on the front panel of the LPT unit into the **OFF** position.

2.0 System Overview

The following paragraphs will provide an overview of each individual system component. Each BATHY-2010 system component has been designed in such a manner as to emphasize performance and flexibility.

2.1 Bathy 2010 Data Acquisition and Playback Unit

The Bathy 2010™ a Windows XP compatible Chirp Sub-Bottom Profiler capable of fully automatic as well as manual operation. The BATHY 2010 is designed for ease of operation and provides a hardcopy interface via a parallel port to gray-shade thermal recorders. The system is capable of real time display of sounding information as well as simultaneous depth digitizing, hardcopy and digital storage. An Ethernet interface (CAT5 /100 Megabit) is available to store or back-up stored SEG-Y Processed or raw data to the vessels network or it can store the data to its internal hard drive. The data back-up can also be transferred to the Bathy 2010's internal CD/DVD RW Drive for data archiving. It also has eight serial communication links for navigation/ position data, ships data, data-logging output, etc. It provides a completely integrated electronic environment with all other survey electronic equipment.

The Bathy 2010 System is packaged within a ruggedized 19-inch rack mount enclosure. The main processing elements are a Pentium 4 CPU Pcb with 1GB of RAM and an embedded TI DSP. One CPU handles serial I/O and data acquisition and processing. The signal-processing element of the BATHY-2010 system The Bathy 2010 design utilizes an extremely flexible / re-programmable DSP architecture. This benefits the user by allowing it the ability to alter many of the Bathy 2010s transmit/receive signal processing characteristics. For example, the low frequency processing channel provides the user with both a linear FM and CW pulse mode of operation. In linear FM mode operation the user may select sweep bandwidths of 1 KHz, 2 KHz and 4 KHz. The user may also select between FM sweep duration's of 5, 10, 25, and 50 msec. CW pulse mode of operation allows for various pulse duration's with matching receiver bandwidths and waveform shapes. Transmit signal synthesis provides modulation and pulse shaping capability as well as pre-distortion of replica waveform to equalize transducer effects. The high frequency processing channel provides the CW pulse mode of operation only. The analog front end provides automatic gain control (AGC), which expands the usable dynamic range of the unit to 144 db. The signal processing hardware utilizes the latest technology including an Intel Pentium 4 and two Texas Instrument DSPs to provide peak performance capability, which exceeds 65 MIPS.

An external sync connection is provided on the Bathy 2010 rear panel to facilitate BATHY-2010 operation with other shipboard acoustic equipment.

Operations and Maintenance Manual

2.2 LPT (Linear Power Transmitter)

SYQWEST, INC. offers a multitude of LPT configurations to suit the individual users needs. The basic building block for the LPT is a 5-kilowatt linear power amplifier module. Configurations providing from 5KW to 30KW are available in 5KW increments. All LPTs are 19-inch rack mountable units.

The LPT utilizes pulse width modulation switching technology. This topography of amplifier, digitally samples the input signal at greater than five times its own frequency with the resultant digital wave train being filtered to reconstruct the original signal at the amplifier output. This results in an efficiency rating of greater than 80% at full rated power. The maximum operating duty cycle is 20% at full power with a 1-50 KHz bandwidth. The LPT offers greater than 70 db operating dynamic range. It receives its input waveform and control signals from the BATHY 2010 via a ground-isolated interface.

The LPT output may be directed to multiple output transducers when the front panel transducer switch option is exercised. The switch is used to select the appropriate output transformer tap for various transducer power levels and impedance's.

-Note-

On Multi-Frequency LPT's, the transducer select switch shall be toggled only after setting the transmit power level parameter to "OFF".

For some systems with simultaneous dual channel transmit capability a 2 kilowatt, Class S type amplifier is included in the LPT unit as well. This transmitter receives control signals from the

BATHY 2010 via a ground isolated interface and provides the output signal for the high frequency output channel.

The LPT is totally protected against adverse loads, over temperature, out of band input signals and loss of primary power. (Refer to APPENDIX C for specific unit details)

2.3 Hardcopy

The BATHY-2010 is capable of interfacing to a variety of industry standard hardcopy devices. The table below lists the devices and their performance characteristics. (Refer to Section 7.1)

Device Type	Technology	Display Area	Resolution
TDU-850	Grey Scale Thermal	8.5 inches	300 DPI
TDU-1200	Grey Scale Thermal	12 inches	300 DPI
TDU-1200F	Grey Scale Thermal	12 inches	203 DPI
TDU-2000F	Grey Scale Thermal	20.16 inches	203 DPI

2.4 TR-109 (3.5KHz Transducer)

The TR-109 is a low frequency transducer suitable for bathymetric and sub-bottom profiling applications. It is rated at a maximum power level of 600 watts at 3.5KHz for a 30% duty cycle (30 degree beamwidth). BATHY-2010 systems use TR-109 transducers in array configurations to provide full power capability for deep water bathymetry and/or sub-bottom profiling. (Figure 7-10)

2.4 TC-12/34 (12KHz Widebeam Transducer)

The TC-12/34 is a dual frequency transducer capable of both 12 and 34 KHz operation suitable for bathymetric survey applications. It is rated at a maximum power level of 2000 watts at 12 KHz (30 degree beamwidth) and 500 watts at 34 KHz (10 degree beamwidth). It is used in the BATHY 2010 system for 12KHz widebeam applications. (Figure 7-12)

2.5 TC-12NB (12KHz Narrowbeam Transducer)

The TC-12NB is a single frequency transducer capable of 12KHz operation suitable for full ocean depth bathymetric survey applications. It is rated at a maximum power level of 2000 watts at 15 degree beamwidth making it the preferred choice for deep water bathymetry. The TC-12NB is used in the BATHY 2010 system for 12KHz narrowbeam applications. (Figure 7-13)

2.6 TC-2084 (33KHz Transducer)

The TC-2084 is a single frequency transducer capable of 33KHz operation suitable for accurate shallow depth bathymetric survey applications. It is rated at a maximum power level of 1000 watts at 20 degree beamwidth making it the preferred choice for shallow water bathymetry. The TC-2084 is used in the BATHY 2010 system for high frequency channel processing. (*not shown*)

2.7 System Power Up and Controls (Power switches and Keyboard)

There are two (2) power up switches that must be turned on for the BATHY-2010 system to start up. There is a switch in the lower left corner of the LPT unit. This switch powers on the LPT unit and enables the 120VAC to the Sonar Unit of the BATHY-2010 system. The other power switch is on the front panel of the the BATHY 2010 Server unit, (under protective shield, loosen (2) captive screws to access). The BATHY 2010 Sonar unit powers on with the LPT, the switch on the front of the Sonar unit is only used when a reset is required..

2.8 System Indicators

Refer to Figure 2-1for front panel indicators on all units.



Figure 2-1
BATHY-2010 CONTROLS AND SYSTEM INDICATORS

3.0 BATHY-2010 SOFTWARE INSTALLATION AND OPERATION

This section describes how to install the Bathy-2010 PC software package. It is assumed that the reader has a working knowledge of installing Windows XP/Vista® software. The installation software is located on the CD-ROM disc included with your Bathy-2010P.

3.1 Installing The Software

NOTE: It is recommended that you exit all running applications before inserting the CD and beginning the installation.

To install the PC software, insert the Bathy-2010 CD into an available drive. If **Auto Insert Notification** is enabled on the CD-ROM drive, then the Bathy-2010 PC installer will begin automatically. If the CD does not auto-start, simply execute the SETUP.EXE file in the root directory of the CD.

Once the installer is running, it will verify that your operating system is compatible with the Bathy-2010 software, and then it will check which version of the Windows Installer program is installed in your system. If the Windows Installer program is not found or out of date, it will update it and prompt you to restart your computer. Once restarted, the Bathy-2010 installation will continue automatically.

The InstallShield Wizard will guide you through the next step where you have the option of choosing an install directory. By default, the Bathy-2010 PC software is installed in the Program Files folder under the sub-directory SyQwest.

In the next step, you may choose a **Typical**, **Minimal**, or **Custom** installation. Selecting Typical will perform a complete install of both the Bathy-2010 application and Sample Data for playback. A Minimal installation will only install the Bathy-2010 application. Additionally, you can choose Custom to manually select what you would like installed. Click the next button to continue to the next step.

The rest of the installation process consists of verifying your settings and clicking the install button. Also, once the installation is complete, you can check the **Launch the program** box to execute the Bathy-2010 software as soon as you close the installer. If not, you can run the Bathy-2010 PC software by using the Windows **Start** button to find the *Bathy-2010* menu under **Programs**, or simply double-click on the *Bathy-2010* icon located on your Desktop.

Operations and Maintenance Manual

3.2 Setting Up The Bathy-2010 Ethernet Interface

3.2.1 Setting a Static IP Address for Network Connection

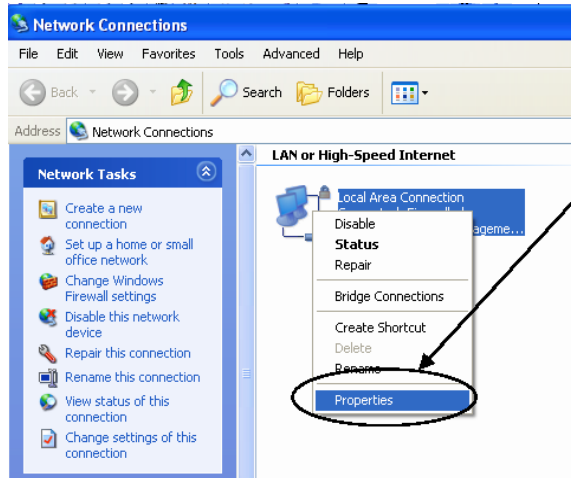

To set up your computer, follow these steps.
Go to: Start Settings Network Connections

Right click on the “Local Area Connection” icon
and select “Properties”
You should see the following screen:

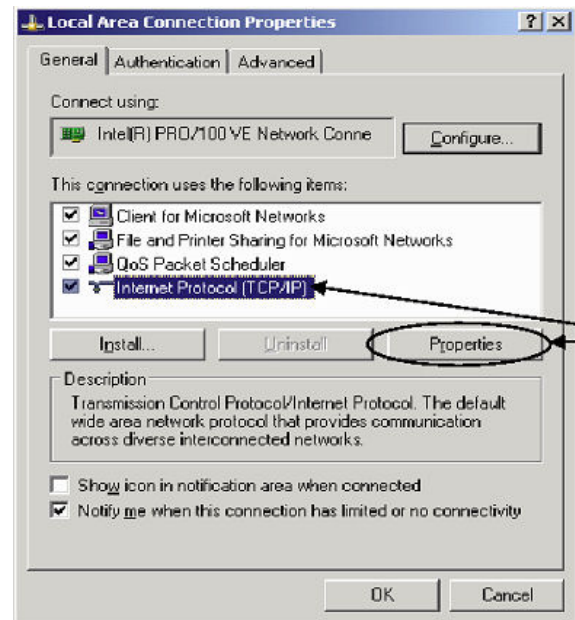

Scroll to and Click on “Internet Protocol” and
then on “Properties”

You should see the “Internet Protocol
(TCP/IP) Properties” window.

Click on the “Alternate Configuration” Tab

You can either set up the interface under the
“General” setup or the “Alternate
Configuration” tab.

If you have 2 or more Network connections
available, you may want to use the “General” settings on your selected Network card.
Click the “Use the following IP address” radio button and set it up with the IP address
shown below (same as the alternate). If you already use that connection, or you are
limited on your network connections, you can select the alternate tab. When selected it
will be displayed with “Automatic private IP address” selected.

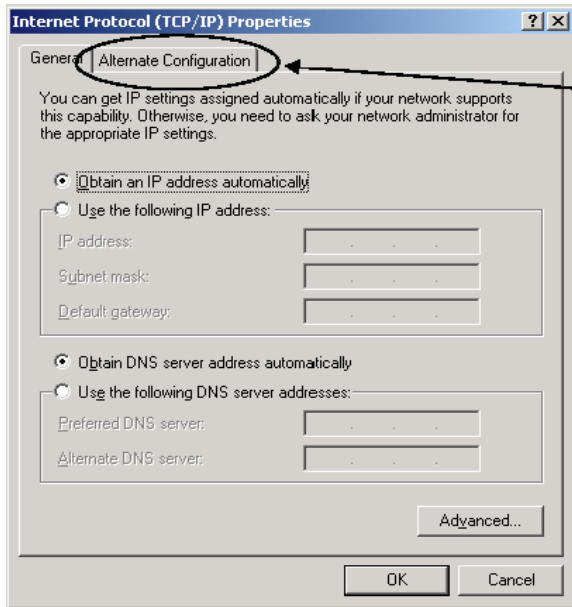

Click the “Use the following IP address” radio button
Enter the IP address information shown below
Select “OK”

For use with the Bathy-2010P, it is required that you use the 192.168.199.113 address.

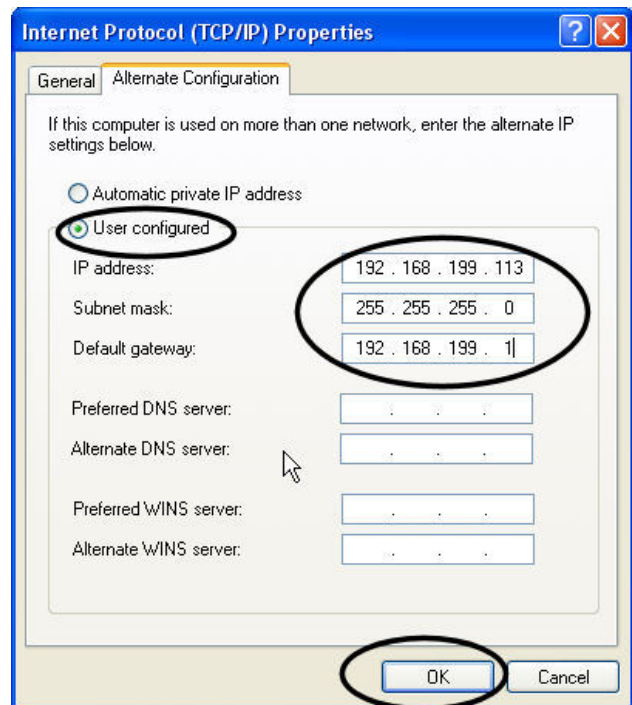

If you have only one network connection, and you move the network cable from your standard network connection to the Bathy when collecting data, you may prefer to set up the “alternate configuration” as shown to the left. This will preserve your “main” network settings, and default to these only when plugged into the Bathy.

3.2.2 Setting an Alternate Static IP Address for Network Connection

If you move your computer from being connected from a LAN using DHCP to your Bathy-2010 or other equipment that uses a static IP address, you can set your computer up to automatically switch to the “alternate” static IP address.

The use of the alternate IP address occurs when the computer cannot find a DHCP server such as when it is connected to your Bathy-2010P.

Operations and Maintenance Manual

3.3 Bathy 2010 P Software Operation

This section describes how to operate the Bathy 2010 Data Acquisition / Playback Unit using the PC Software package included with your Bathy 2010.

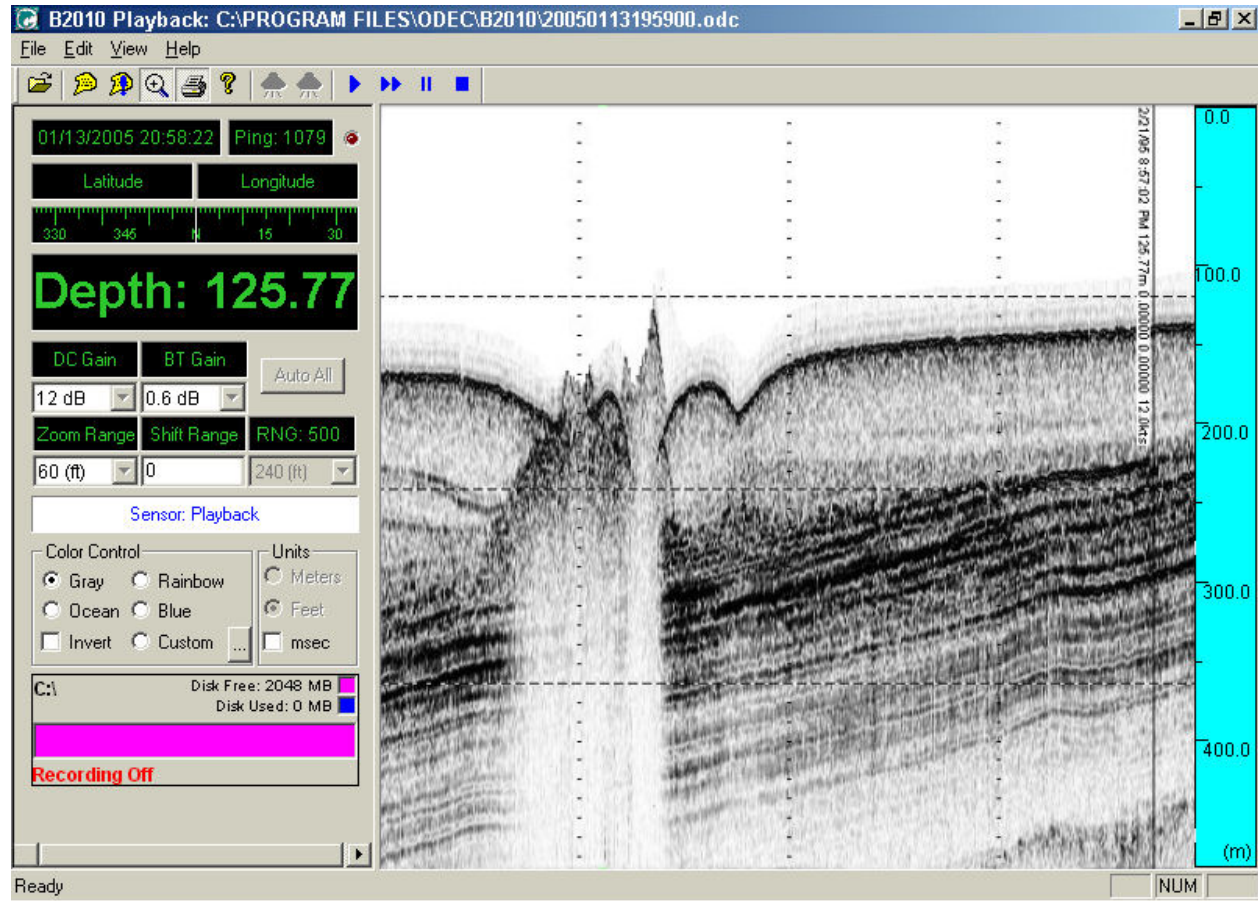

Figure 3-1 Main Window

3.3.1 - The Main Window

The Bathy 2010 Main interface is divided into two fields, the **Controls and Status** field, and the **Data** field. The vertical window boundary between the fields may be positioned by the user as desired.

The **Controls and Status** field is located in the left portion of the window. It provides access to all of the user controlled parameters. Specifically, the **Controls and Status** field includes digital depth, an animated compass with heading marks in degrees, GPS Position, Time/Date, Ping Count, available disk space (for data storage), and Bathy 2010 Data Acquisition / Playback Unit status.

The **Data** field is located in the right portion of the window. It displays the actual echo data. The **Data** field can be viewed in either *Normal* or *Zoom* mode. In Normal Mode, the entire **Data** field is used for displaying non-zoomed bottom data. In Zoom Mode, the **Data** field is divided in half to show zoomed data on the left and normal bottom data on the right. While echo data is being shown in either mode, the user may use the mouse to obtain a digital depth value anywhere in the water column by pointing and clicking. See the below picture and table for more info. (The picture reflects the software in Zoom mode)

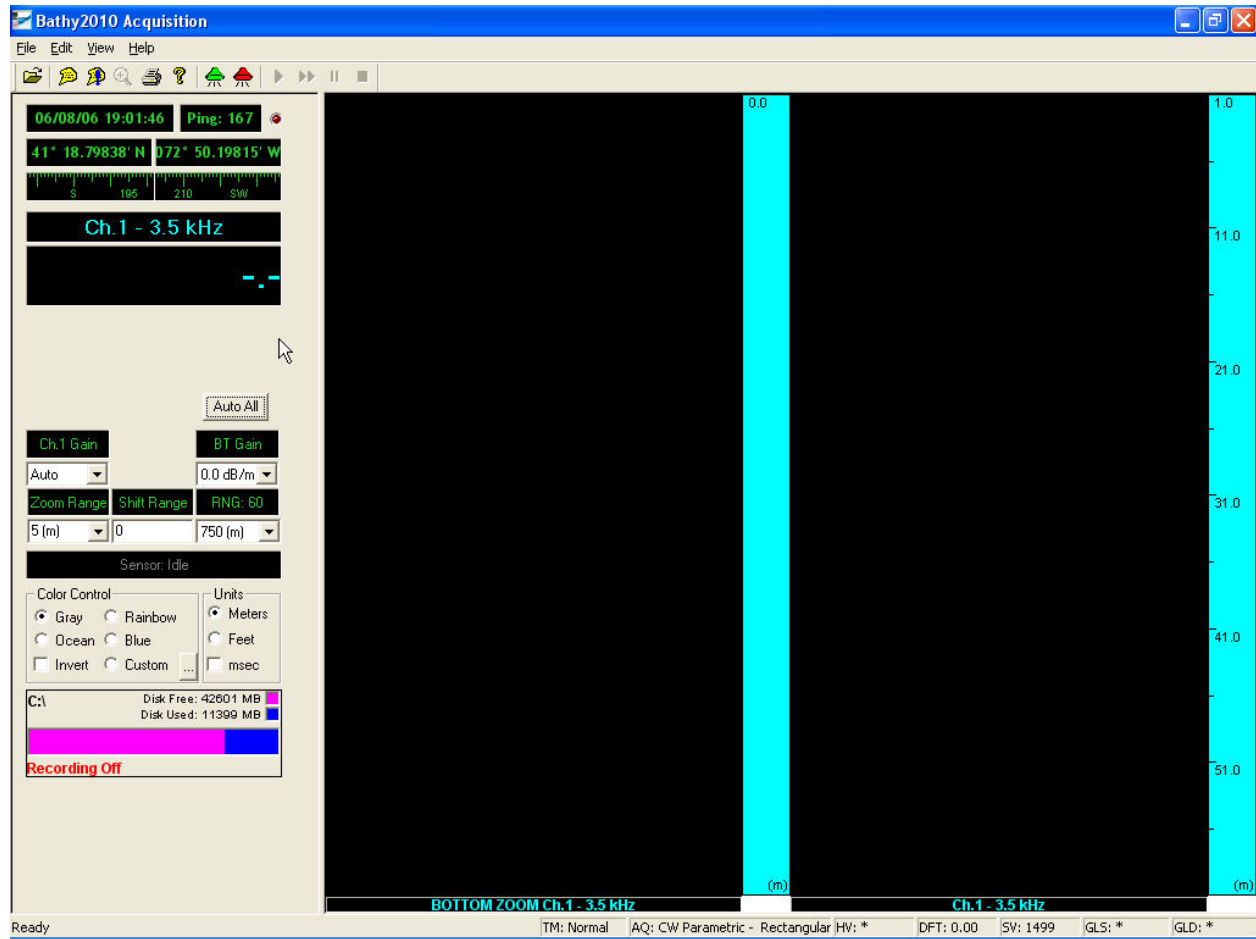















Figure 3-2 Zoom Mode

NOTE: The current on-screen bottom image in both Zoom and Data windows will be lost upon resizing the window

Operations and Maintenance Manual

1. The Toolbar

Quick access to common Bathy 2010 functions. From left to right they include:

	Open A Playback File
	Capture Screen
	Insert Text Annotation
	Insert Manual Event Mark
	Toggle Playback Zoom
	Toggle TDU Printer On or Off
	Get Bathy 2010 Software And Version Info
	Starts the Bathy 2010 Data Acquisition / Playback Unit Pinging
	Stops the Bathy 2010 Data Acquisition / Playback Unit Pinging
	Playback a Previously Recorded File
	Toggle Fast Forward/Normal Playback
	Pause Playback
	Stop Playback
	Playback Slide Bar

NOTE: Playback buttons are available in Playback mode only and will be disabled otherwise.

2. Function Key Controls

The Function Keys on the Keyboard are setup to allow the operator easy access to the most frequently used parameter controls in the Bathy 2010 system. A mouse or trackball can be used to access all of the parameters as well but often in shipboard conditions, the use of pointing devices can be difficult so having “Hot Keys” is beneficial.

Function Keys F1 through F11 are all available and the use of each is described on the list below:

F1 – Gain

- **F2** – System Range
- **F3** – System Power Level
- **F4** – BT Gain
- **F5** – Playback, Play Button
- **F6** – Playback, Fast Forward Button
- **F7** – Playback, Pause Button
- **F8** – Playback, Stop Button
- **F9** – Manual Event Mark
- **F10** – Manual Annotation
- **F11** – Toggle Auto All Button

Operations and Maintenance Manual



Capture Screen Shot

The Capture function is a very useful feature. By depressing the Camera Icon on the Tool Bar, the user will cause a Screen Shot of the entire BATHY-2010 display to be sent to the path selected in the User Preferences dialog box. The file format for the Screen Shot is Jepeg and thus can be shared and viewed using any standard picture viewing software package. The file name for the screen shot reflects the date and time of capture:

YYYYMMDDHHMMSS.jpg where:

YYYY - 4-digit Year
 MM - 2-digit Month
 DD - 2-digits Days
 HH - 2-digits for Hours
 MM - 2-digits for Minutes
 SS - 2-digits for Seconds
 .jpg - Standard Jepeg File extension

The Capture Screen Shot feature is most useful for storing historical information as it provides an instantaneous shot of any interesting bottom contour activity. When used in conjunction with a GPS (the position will be stored in the screen shot as well if a GPS is connected), the exact location, date, and time are all accessible at a moments notice

3. Navigation/Depth Display

These indicators provide navigation and digital depth info to the user in real-time. Navigation/Depth information includes the digital depth, current Date/Time, global position, and ping count.

The digital depth is shown to 1 decimal place in both Feet and Meters and is displayed in a large font to make viewing easier from a distance. The depth value is updated once per ping and will show -.- if the depth is not found or invalid.

The Date/Time shown is based on the user's PC clock by default and can be displayed in Local time or GMT. Position info is also provided when a GPS receiver is connected to the PC and the Bathy 2010 Software is configured and receiving valid GPS data. When GPS Position data is not available, the display will show "Latitude N/A" and "Longitude N/A". If the Bathy 2010 PC Software is receiving position data, it will be provided in Decimal Minutes format. (i.e. 41° 22.74402' N, 71° 36.25902' W)

The ping count is included to provide the user with a means of estimating how fast the Bathy 2010 Data Acquisition / Playback Unit is pinging, and also for how long. The ping count is reset to zero when any of the following events occur:

- The Bathy 2010 Software is restarted.
- A Recording or Playback file has begun.
- The Bathy 2010 Data Acquisition / Playback Unit has temporarily lost power and reset.

In addition, the Bathy 2010 software features an animated compass, which displays the current heading. The compass is located underneath the GPS position information.

4. Gain and Auto Controls

The Gain controls consist of 2 pull-down menus, which control the Bathy 2010 Data Acquisition / Playback Unit's gain settings. The Bathy 2010 *Hardware* gain is controlled by the **Ch. 1 or Optional Ch. 2 Gain** control and can be set either from 0-75 dB, or to Auto Mode. The **BT Gain** controls the *Bottom Triggered* gain, which allows the user to amplify acoustic returns in the sub-bottom sediments. The **BT Gain** is first applied at the bottom depth value and increases over time at the selected dB/unit increment. It can be set from 0.1 - 2.0 dB/unit (Either Feet or Meters, depending on which is currently enabled) in 0.1 increments. For example, consider the following:

Bottom Depth is 40.0 meters

Range is set to 0 - 80 meters

BT Gain is set to 0.5 dB/m

Ch. 1 or Optional Ch. 2 Gain is set to 30 dB

From 0 – 40 meters, the total gain will remain 30 dB as set by the **Ch. 1 or Optional Ch. 2 Gain** control. After 40 meters, however, the total gain will increase by 0.5 dB every meter, giving you 35 dB of total gain at 50 meters, 40 dB at 60 meters, etc. The **BT Gain** can only apply up to 30 dB of additional gain.

Depressing the **Auto All** button sets the Bathy 2010 Data Acquisition / Playback Unit to automatically choose the best Range (Refer to next section for more information on Range) and hardware Gain settings, making bottom tracking easier for the user. Clicking the **Auto All** button again will toggle the Bathy 2010 back to manual mode.

The **BT Gain** is not auto-controlled in Auto All mode. This allows the user to select the BT Gain best suited to the bottom features present for their application.

NOTE: When in Auto All mode, the Ch. 1 or Optional Ch. 2 Gain control is not available and will be controlled by the Bathy 2010 automatically. While the control is disabled, it will indicate which hardware gain setting that the Data Acquisition / Playback Unit has chosen.

5. Range, Zoom Range, and Shift Controls

The **Range** control allows you to choose a manual range for the Bathy 2010 Data Acquisition / Playback Unit. It includes 6 range settings presented in either Feet or Meters.

Operations and Maintenance Manual

The **Zoom Range** control has 5 settings which are used to set the range of the Zoom window. These values will be in either Feet or Meters depending on which units are currently selected.

The **Shift Range** control allows you to choose a manual offset to the start depth on the graphic display. The user enters an integer value, in either Feet or Meters depending on which is currently selected, to set the top of the water column. The water column viewed will reflect the shift depth at the upper limit of the display and will extend the entire range amount.

For example, if a range of 0 – 80 meters is selected, and a Shift value of 10 is selected, the water column range will become 10 – 90 meters. The Shift value cannot exceed 450 feet, or 150 meters. It will also NOT be available nor have any effect while in **Auto All** mode.

NOTE: When in Auto All mode, the Range control is not available and will be controlled by the Bathy 2010 automatically. While the Range control is disabled, it will indicate the current Range setting that the Data Acquisition / Playback Unit has chosen. Shift Range will also not be available nor have any effect in Auto All mode.

Data Acquisition / Playback Unit State

This indicator shows the current state of the Bathy 2010 Data Acquisition / Playback Unit. There are a total of 6 different states:

Unknown	- No communication is present between the Data Acquisition / Playback Unit and the Bathy 2010 Software.
Power On	- Power has been applied to the Bathy 2010 and the Data Acquisition / Playback Unit has begun communicating.
Initializing	- The Bathy 2010 software is handshaking with the Data Acquisition / Playback Unit to establish a reliable connection.
Idle	- A connection between the Bathy 2010 Software and the Bathy 2010 Data Acquisition / Playback Unit has been established, but no commands have been received yet.
Pinging	- The Bathy 2010 Data Acquisition / Playback Unit is transmitting and receiving real-time bottom data.
Playback	- The Bathy 2010 Software is displaying previously recorded data from a playback file.
Post Failure	- The Bathy 2010 Data Acquisition / Playback Unit did not pass the initial Power On Self Test. This error will always include an error code.

6. Color Palette and Unit Controls

The Bathy 2010 PC Software allows you to choose from 4 standard 256 level color palettes by clicking on one of the radio buttons located in the **Color Control** section. If you wish to create your own palette, you can do so by selecting **Custom** and clicking on the button to right of it. You can also reverse the current palette by using the **Invert** box.

Along side the Color Control is the Units control. You can choose to display depth and range information in Feet or Meters. You can also check the Milliseconds box to display range and zoom range scale bars in Milliseconds rather than Feet or Meters.

7. File Capture Status

This unique feature allows the user to view the Recording status when capturing data to a hard disk. The status shows the drive letter of the destination drive as well as a graph depicting how much free/used space is present on that drive. During recording, the current file size will be shown also.

8. Range Markers

These scalebars show the full range of the data windows and are based in the current unit selected. Also, if GUI Zoom is activated, two slider bars will be visible on the right scalebar. They are used to specify the GUI zoom window boundaries. In addition,

when Marker Zoom is enabled, a single slider bar will appear and is used to specify where the water column will begin in the marker zoom window.

9. Mouse Depth/Position Fields

These fields are where the actual echo return data appears in the Bathy 2010 PC Software. By using the mouse, the user may obtain a digital depth value anywhere in the water column by pointing the mouse cursor. In the lower right side of the window containing the digital depth value in feet or meters, depending on which has been selected and their Longitude/Latitude position. This window may be conveniently moved anywhere on the screen and will remain open until it is closed.

NOTE: To fine-tune in on a depth value, the user may point, click the left mouse button, and HOLD it down while slowly moving the mouse pointer. The digital depth shown in the Mouse Depth display will be continuously updated.

Operations and Maintenance Manual

3.3.2 – MENU BAR

File Menu



Start/Stop Recording-

Creates a new file on the specified hard disk for capturing acquisition data. If the Bathy 2010 Data Acquisition / Playback Unit is already pinging, then the software will start the data recording immediately. The

filename is based on the date/time in the following format:

<path>YYYYMMDDhhmmss.odc

<path> - This represents the path to a directory where the recorded files should be stored. Refer

to **User Preferences** in this section for information on manually setting the path.

YYYY - 4-digit Year

MM - 2-digit Month

DD - 2-digits Days

hh - 2-digits for Hours

mm - 2-digits for Minutes

ss - 2-digits for Seconds

.odc - SYQWEST, INC.'s Proprietary File Extension

.seg - Standard SEG-Y format

NOTE: Once recording is started, this option will become “Stop Recording”.

Open for Playback- Allows the user to select a stored SEG-Y file from file storage for playback and Post-Processing.

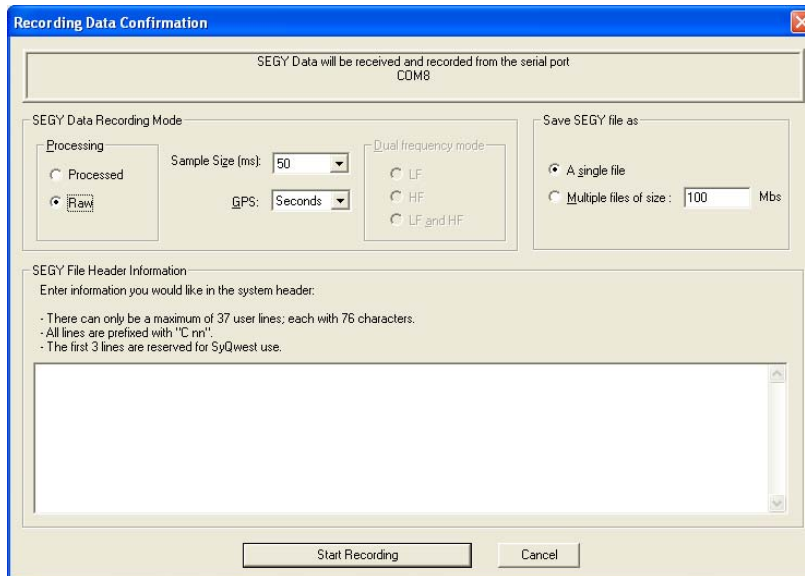

Recording Data Confirmation- Allows the user to select the data storage format, file size and annotate SEG-Y header information.

Recent Files

The Bathy 2010 software keeps a list of the 4 most recently opened playback filenames for easy access. These filenames are found between the “User Preferences” and “Exit” menu options. Clicking one will immediately begin playback of the file.

Exit

You can exit the Bathy 2010 PC Software by either using the “Exit” on this file menu, or by simply clicking on the windows default close button.

Operations and Maintenance Manual

3.3.2.1 Edit Menu

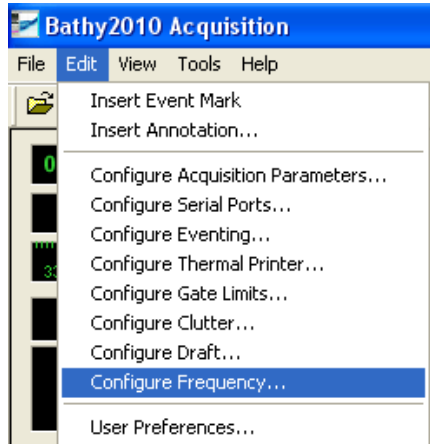

Insert Event Mark

Selecting this option will generate and insert a formatted event mark on the display, in the recorded file (if recording is on), and if enabled, the thermal printout. The event mark contents can be configured by selecting “Configure Events...” under the File menu. In addition, an event mark can also be inserted by clicking the corresponding toolbar button. (See Section 3.3.1)

Insert Annotation

Selecting this option will allow you to enter a custom text message to be inserted on the display, the recorded file (if recording is on), and if enabled, the thermal printout. In addition, annotation text can also be inserted by clicking the corresponding toolbar button. (See Section 3.3.1)

Configure Acquisition Parameters- Allows the user to select the Operational mode, Pulse Window, Power Level, Sweep Bandwidth and Detection Threshold adjustments.

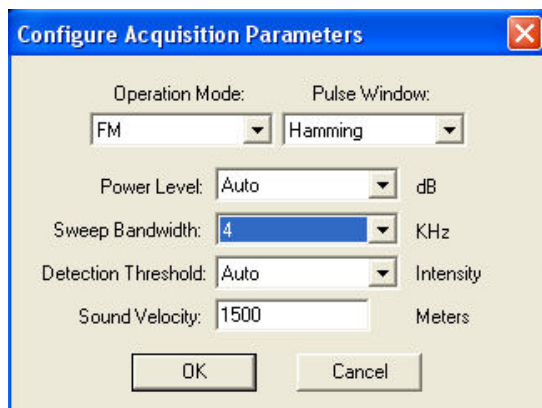

Operating Mode- Selects transmit waveform and detection processing mode of operation. Selectable modes are: CW (parametric and nonparametric transmissions) as well as FM sweep (parametric or non-parametric transmissions).

Transmit Mode- Active or Passive Pinger mode. In active mode the system provides the

transmit waveform while in pinger echo sounder mode, the system automatically synchronizes to and passively processes a periodic active acoustic pinger source.

Transmit Rate- The transmit pulse repetition rate varies from .1hz to 4hz dependent on depth range and selected pulse length.

Pulse Length- Allows the user to select pulse lengths most suitable to the operating mission and environment. Selectable pulse lengths are: - Auto or Manual (.2ms, .5ms, 1 ms, 2ms, 5ms, 10ms, 25ms, 50ms).

Pulse Window -Transmit waveform shaping is provided to allow for maximum average power or a reduction in range side lobes, resulting in higher resolution sub-bottom profiles and slope tracking. Selectable windows are: Rectangular, Cosine, Hamming, or Blackman

Sound Velocity- Allows the user to adjust the speed of sound adjustment 1400-1600 meters/second or 4595-5250 feet/second, in 1 unit increments.

Sweep Bandwidth- FM sweep frequency bandwidth.

User selectable bandwidths are: Auto, 1 , 2, 4 and 8kHz

Configure Serial Ports- Allows the user to select the serial inputs and output as required for Navigation, Data Logging, Heave, External Events, Sonar Port and SEG-Y storage settings.

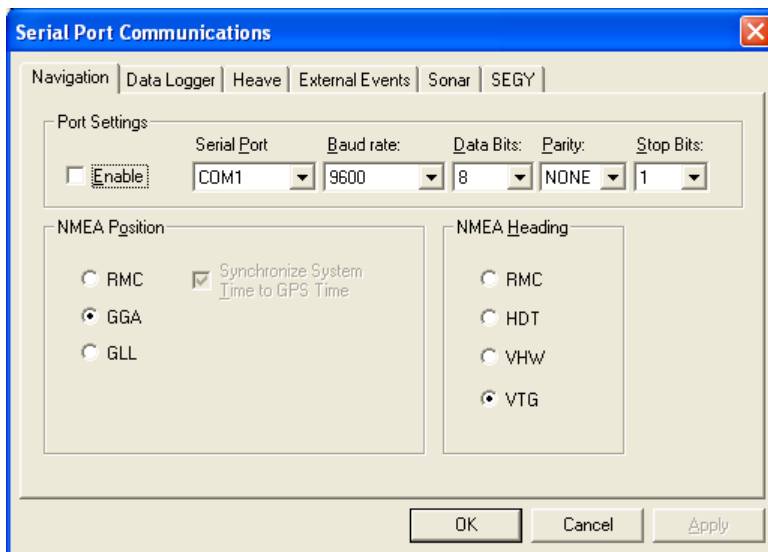

Operations and Maintenance Manual

Configure Eventing- This menu is used to configure eventing and annotation.

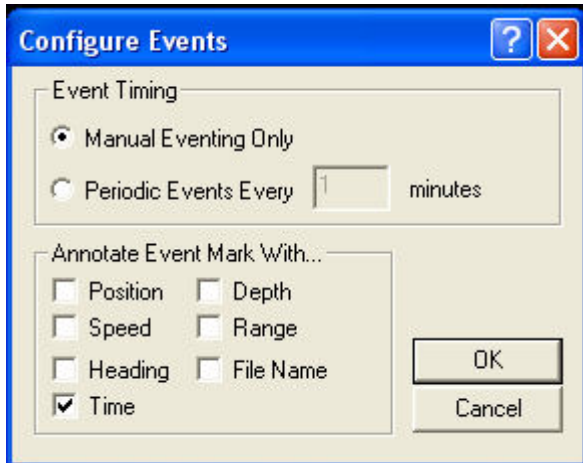

Events may be generated by using the toolbar button, or the corresponding menu option “Insert Event Mark” under the *Edit* menu. An event is a vertical marker which appears on both the screen and printer. A number of real-time parameters may be included with the events as derived by the user. These parameters are shown in the previous picture under “Annotate Event Mark With...”. In addition, the user may choose between 3 Eventing trigger methods

including, *Manual*, *Periodic*, or *External*. When in “*Manual Eventing*”, event marks are inserted only when one is requested by the user using one of the methods described above.

“*Periodic Eventing*” allows the Bathy 2010 software to insert events at a specific interval, depending on the number of minutes entered by the user. While in periodic mode, the user may still insert manual event marks in addition to the periodic ones. “*External Eventing*” has been implemented as means of allowing third party software, such as HyPack, to remotely generate Event marks and annotation in the Bathy 2010 software. It can be configured by enabling the “*External Eventing*” option and setting the communication parameters such as COM Port, Baud Rate, Start Bits, Stop Bits, and Parity to match the configuration of the third party software. The Bathy 2010 accepts external annotation/eventing with the following format.

(CTRL F) (CTRL A) (Annotation String) (CTRL D) - Generates an event mark containing the text in the Annotation String

(CTRL F) - Generates an empty event/fix mark

NOTE: Periodic Eventing is not available when External Eventing has been enabled.

NOTE: All event marks and text annotation shown on the screen are inserted BETWEEN the acquired bottom data so that there is no loss of information.

Configure Thermal Printer- Allows the user to select to choose the model of Thermal Printer used for hardcopy recording and the recorder settings.

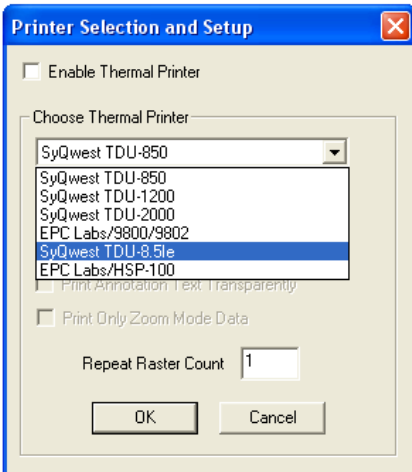

This menu allows you to configure a thermal printer for use with the Bathy 2010 software. It supports assorted thermal printers including 3 different models from the Raytheon/SYQWEST, INC. TDU series, the TDU-850, TDU-1200, and the TDU-2000.

In addition to Enabling or Disabling the printer, there are a number of other options available to the user. These settings only affect the thermal printout, not the on-screen display. They include:

- Display Negative Image
 - Enabling this option will invert the gray scale colors on the thermal printout.
- Flip Rasters Left to Right or Top to Bottom
 - Enabling this option will print a mirror image of the event/annotation marks. This option is to be used in conjunction with the L/R dip switch located on the back of the TDU Printer (Refer to your TDU Manual for more information). By default, the switch is set to the L position and so this option should not be enabled. However, if the dip switch is set to R, enable this option to print the event/annotation marks correctly.
- Print Grid Lines and Range Markers
 - Enabling this option will print the data along with 4 grid lines and periodic range markers.
- Print Annotation Text Transparently
 - By default, this option is not enabled and annotation is printed with a solid background so that the text is always readable. This will cause some bottom data not to be shown on the printout, but will still be present on the display and recording file (if recording is on). Enabling this option will print annotation text without a solid background. This may make annotation text hard to read when printed over bottom data.
- Repeat Raster Count
 - A Repeat Raster Count can be entered between 1 and 10. The default count is 1 Raster. Increasing this value will cause the printout to be stretched horizontally. This option is useful when using a TDU-1200 or TDU-2000 printer which has a finer vertical resolution. (i.e. Pixels are small)

Operations and Maintenance Manual

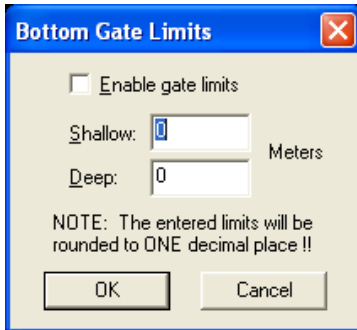

Configure Gate Limits- Allows the user to select to the minimum and maximum limits on which the Bathy 2010 will look for a valid bottom return.

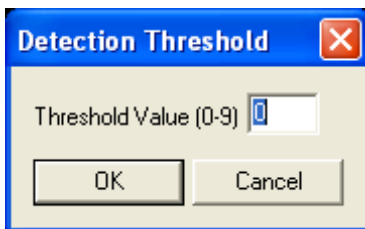

Detection Threshold – The Detection Threshold value is provided to allow the user to vary the echo reply level that is recognized by the Bottom digitizing function as a valid bottom echo. For some bottom conditions the default value of “0” is fine for bottom digitizing.

The “0” setting sets the digitizer to the higher threshold, which works well in moderate and deeper depths. In shallow water and soft sediment survey conditions a lower threshold is required to consistently digitize on the bottom without saturating the first few meters of strata penetration. The Detection Threshold value can be varied from 0 -> 9 with 9 representing the lowest echo threshold.

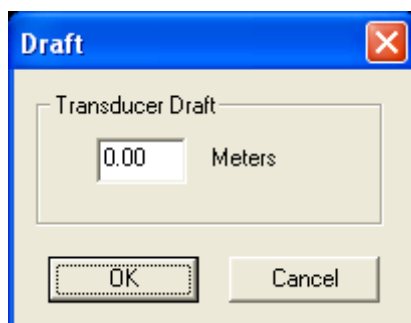

Configure Draft - Allows the user to compensate all sounding data for transducer location and ship's draft. User entered value.

Configure Frequency

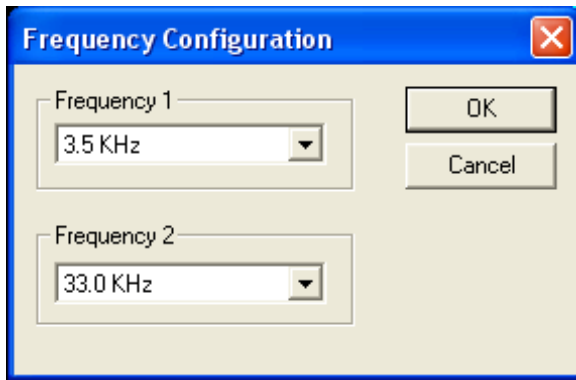

The Frequency Configuration control is accessed by selecting “Configure Frequency...” from the Edit menu. B2010/B2010 systems are sold in a host of configurations based on customer needs and operating budgets. Many systems are sold as Single Channel, Single Frequency which suffices for most Sub-bottom applications. Some systems are configured for Multi-Frequency operation and Dual

Channel operation as well. The Multi-Frequency and Dual Channel system variants require a user control for the selection of the transmit and receive frequency for Channel 1 and/or Channel 2 (Dual Channel systems). The frequency selections available for each Channel are exhibited in the Frequency Configuration dialog box as shown below. The user simply selects the desired frequency from the drop down box and then depresses the “OK” button. When the frequency is changed by the user, the B2010/B2010 GUI provides visual feedback of the update in three locations: Text underneath the Acoustic Data display window, Text above the Digitized Depth Box, and Text for the appropriate Channel (1 or 2) on the View menu. Once the frequency is updated by the user, all transmission and reception on the appropriate channel will be done at the selected frequency. In FM mode, the frequency selected will be the center frequency of the CHIRP waveform.

User Preferences

This menu allows you to configure recording and playback options. By selecting “Playback files continuously”, the current playback file will repeat from the beginning when it reaches the end. The Bathy 2010 software stores recorded data files in the same directory as the application by default, however, you can select an alternate location by clicking the “Browse” button and specifying another directory. Additionally, you can limit the maximum recorded file size by enabling the “Automatic File Size” option. If the recording file reaches the specified size, it will create additional files to save the remaining data. This option is useful if your data will be transferred to removable media where space is limited.

The “Time Display” control allows the user to specify which Time Zone the Date/Time should be based on. The Date/Time shown on the display will also be the value recorded to a file if recording is active. Choosing “Local Time” will enable whichever Time Zone is currently selected in the Windows operating system. (Refer to your Windows User Guide for more information regarding Time Zones). Selecting “UTC Time” will display Date/Time information based on the GMT Time Zone.

**Operations
and
Maintenance Manual**

This menu also allows the user select the Alarm Count which is a threshold on which if the bottom is lost for a user selectable number of pings the Bathy 2010 will then signal; bottom lost.

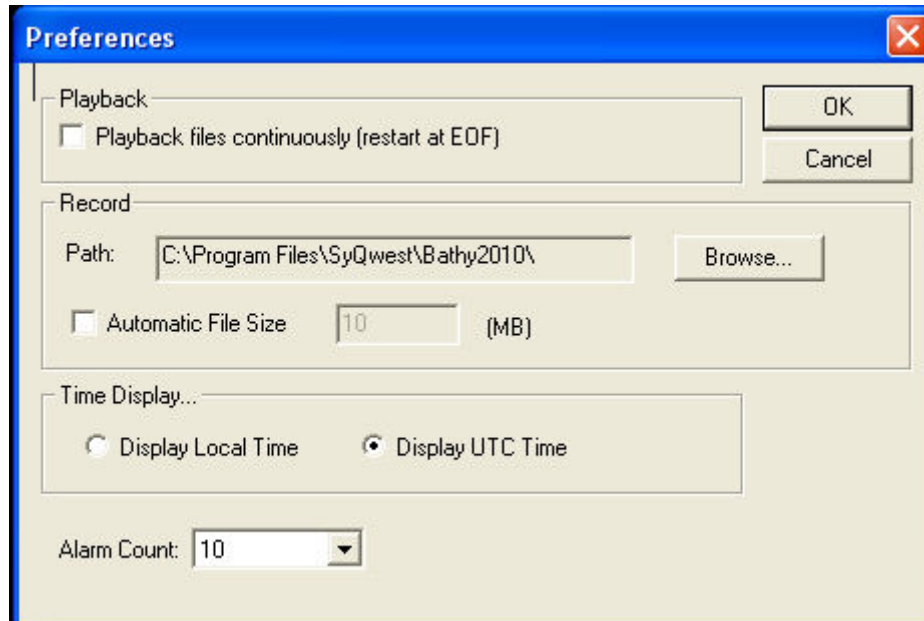

3.3.2.2 View Menu

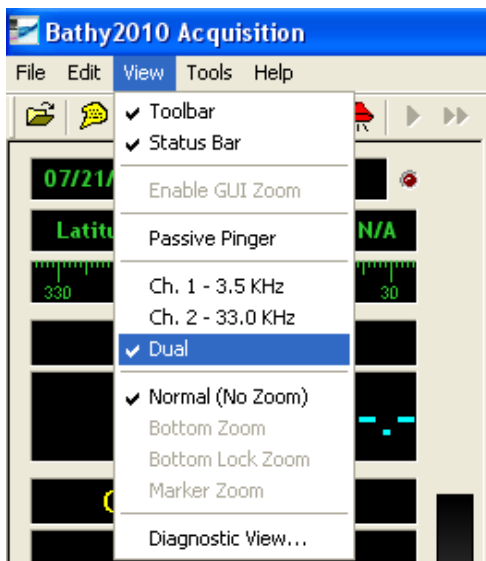

Ch. 1 Only – Allows the user to display the Bathy 2010’s Low Frequency Channel. Available frequencies are: 3.5, 12, 16, or 33 kHz

(Optional) Ch. 2 Only - Allows the user to display the Bathy 2010’s High Frequency Channel., available frequencies are: 12,16,18,33 or 34 kHz

Dual Channel - Allows the user to display the both of the Bathy 2010’s High and Low Frequency Channels. **(Optional)**

Zoom Modes –Allows the user to display the Bathy 2010’s High or Low Frequency Channels in a zoom window.

Enable GUI Zoom

This option allows the user to digitally scale bottom data from a playback file and can function as a manual zoom. This feature was included in order to provide a method to zoom in on bottom data previously recorded without one of the Bathy 2010 Data Acquisition / Playback Unit's enhanced zoom modes enabled. When enabled, two zoom bars will appear on the scalebar of the Normal Data window. These bars can be dragged up or down in order to set the GUI zoom range. Data displayed in GUI Zoom is derived from recorded Normal data.

Display Modes

The Bathy 2010 Data Acquisition / Playback Unit features an enhanced multi-mode zoom. It provides a smooth, magnified high-resolution window of the bottom. The enhanced zoom modes are acquired in real-time and are displayed/recorded at higher sample rates than the Normal data (assuming the zoom range is smaller than the normal range).

There are 4 display modes available with Bathy 2010 software, including 3 Zoom modes, and 1 without any zoom. They include:

Normal

This mode displays the normal bottom data by itself without any zoom information. When selected, this mode will use the entire viewing area.

Bottom Zoom

When selected, this mode will split the viewing area in half. The left side will be used to show zoom information, and the right side for normal bottom data. Bottom Zoom mode centers the zoom display around the current depth allowing you to follow it up and down the water column at a high resolution. In addition, the user can use the Zoom Range Control to zoom in or out. The Zoom Range value represents the zoom range in whichever units are currently selected. When the zoom window moves up or down to track the bottom, it does so in Zoom Range / 2 increments.

Bottom Lock Zoom

This mode functions the same way as Bottom Zoom, however it does not show the bottom moving through the water column. Instead, it will lock the bottom to the upper portion of the zoom view so that the user may continuously monitor sub-bottom information.

Operations and Maintenance Manual

Marker Zoom

Like in the other modes, Marker Zoom provides a high-resolution zoomed view of the water column, however in this mode, the user can specify where in the water column the zoom range will begin. This is accomplished by dragging the marker zoom bar up or down the normal view scalebar to the point you want the zoom range to begin. The start of the zoom range can be observed at the top of the zoom window while you drag the marker zoom bar, but the marker zoom isn't set until the mouse button is released.

3.3.2.3 Help Menu

This menu includes a software Help guide along with an About Bathy 2010 option. Clicking it will display a window with information such as the Bathy 2010's software version and SyQwest, Inc.'s company information. In addition, the software will request and display Hardware/Firmware version information from the Bathy 2010's DSP to ensure it is connected and communicating properly.

3.3.2.4 SEG-Y File Storage Format

1.0 Reel Identification Header Part1

C1	80 ACSII Bytes per line
.	.
.	.
.	.
.	.
C40	.

Total of 3200 bytes within this header.
One header per file.

2.0 Reel Identification Header Part2

Byte # Description

3200-3204	job id=1
3205-3208	line =0
3209-3212	reel=1
3213-3214	traces/record=1
3215-3216	aux traces/record=0
3217-3218	sample interval in microseconds=50
3219-3220	sample interval in microseconds=50
3221-3222	number of samples within a data trace = 1000 (50ms) or 2000 (100ms)
3223-3224	number of samples within a data trace=1000 (50ms) or 2000 (100ms)
3225-3226	fixed point representation (2 bytes)=3
3233-3234	sweep frequency at start of sweep=2750

3235-3236	sweep frequency at end of sweep=3750,4750or 6750 Hz
3237-3238	sweep length=5,10,25 or 50 mSec.
3239-3240	sweep type,linear=1
3249-3250	correlated=2
3251-3252	binary gain recovered=2 ,no
3253-3254	amplification recovery record=1,none
3255-3256	units:1=meters,2=feet

3.0 Trace Identification Header

<u>Byte #</u>	<u>Description</u>
5-8	trace sequence number this reel
49-52	source depth
61-64	water depth at source
73-76	longitude coordinate 32 bit floating point
77-80	latitude coordinate 32 bit floating point
109-110	delay to recording time in mSec
127-128	start sweep frequency=2750
129-130	end sweep frequency=3750,4750 or 6750 Hz.
131-132	sweep length=5,10,25, or 50 msec.
157-158	year
159-160	day of year
161-162	hour
163-164	minute
165-166	second
201-240	trace annotation
241-x	trace data samples
x to x+320	playback parameters

3.3.2.5 Navigation input

The Bathy 2010 accepts ship's position and heading interface via serial data from several external devices including DGPS Positioning Systems and Heave Compensators. The position and heading data is displayed on the BATHY-2010 main display and is stored to the harddrive or network storage for playback when storage is being utilized. There are currently three selectable software protocols available via the Serial Port Configuration Menu under the Navigation tab. PMC, GGA and GLL. The hardware characteristics are the same for all three and are exhibited below:

Hardware Characteristics

Data Bits Per ACSII Character	User Selectable
Start Bits	User Selectable
Parity	User Selectable
Stop Bits	User Selectable

GGA - essential fix data which provide 3D location and accuracy data.

\$GPGGA,123519,4807.038,N,01131.000,E,1,08,0.9,545.4,M,46.9,M,,*47

Where:

GGA Global Positioning System Fix Data
123519 Fix taken at 12:35:19 UTC
4807.038,N Latitude 48 deg 07.038' N
01131.000,E Longitude 11 deg 31.000' E
1 Fix quality: 0 = invalid
 1 = GPS fix (SPS)
 2 = DGPS fix
 3 = PPS fix
 4 = Real Time Kinematic
 5 = Float RTK
 6 = estimated (dead reckoning) (2.3 feature)
 7 = Manual input mode
 8 = Simulation mode
08 Number of satellites being tracked
0.9 Horizontal dilution of position
545.4,M Altitude, Meters, above mean sea level
46.9,M Height of geoid (mean sea level) above WGS84
 ellipsoid
(empty field) time in seconds since last DGPS update
(empty field) DGPS station ID number
*47 the checksum data, always begins with *

Operations and Maintenance Manual

3.4 Heave Data

The BATHY-2010 system provides a serial data channel for receiving heave information from a Ship's Motion Sensor or Vertical Reference Unit. For high resolution survey requirements the heave input is used to correct the digitized depth values and the real time sounding data for the vertical motion of the vessel. The Heave value is displayed on the system video monitor as well.

The user can configure and enable the ship's motion serial interface as required under the Serial Port Communication menu under the Heave tab and will use the data for depth processing. The serial data format for the motion data output is based on the serial output of a VT/ TSS DMS-5 Roll-Pitch-Heave Sensor.

The transmission format for the serial data channel is exhibited below:

Transmission Format

Data Bits Per ACSII Character	User Selectable
Start Bits	User Selectable
Parity	User Selectable
Stop Bits	User Selectable
Baud Rate	User Selectable
Voltage Levels	RS-232

Software Protocol

```
:XXXXXXSMHHHXXXXXXXXXXXXX<CR><LF>
```

-Note-

"S" in the above string is always a data delimiter

"X" is a don't care, however, it must be filled with data

:	Record Start Character
XXXXXX	Don't Cares (Not used by BATHY-2010P)
M	Sign of Heave (<SP> if positive, else "-")
HHHH	Real-Time Heave in CM
XXX-->X	All X's are Don't Cares (Not used by BATHY-2010P)
<CR><LF>	Carriage Return, Line Feed Record End Characters

3.5 Digitized Depth

The bottom tracker displays digitized depth or blanks this field when it has lost the bottom echo return. In pinger mode the field displays the digitized pinger height from the ocean bottom depth.

3.6 External Synchronization

The BATHY-2010 provides two interface signals to synchronize to other sonars.

4.0 (Data Logger) Serial Input/Output Protocol

The BATHY-2010 provides digitized depth and operating mode parameter data via an RS-232 serial output. This serial ASCII data output string can be programmed by the operator via the Serial Port Communication menu under the Data Logger tab to provide one of four types of fixed string length outputs. The first type of string contains digitized depth and time/date tags while the second type of string contains this information plus encoded operating parameter data. The operator can disable serial output data transmission via the operating mode menu upon demand. The serial port is full duplex and allows the user to input a data string for chart annotation and to set system time/date. The following is a synopsis of the Data Logger Serial I/O Protocol for both single and dual channel sounders.

Hardware Characteristics (All Data Formats)

Data Bits Per ASCII Character	User Selectable
Start Bits	User Selectable
Parity	User Selectable
Stop Bits	User Selectable
Baud Rate	User Selectable
Voltage Levels	RS-232

PMC Depth (dt) Format

Sample data strings

FDT L 11.1 FT EDT H 0.0 FT DT H 21.0 FT DT L
11.1 FT

Proprietary depth output string. Format described below.

Single Frequency Operation	Dual Frequency Operation
D T _ x x x x . x _FT <CR><LF> (English mode)	_D T_f _ x x x x . x _FT <CR><LF>
D T _ x x x . x x _MT <CR><LF> (Metric mode)	_D T_f _ x x x . x x _MT <CR><LF>

During normal operation the "space" in front of the "D" will be blank; An "E" in this space indicates an error such as lost bottom while an "F" indicates a Fix Mark. The second character after the "T", represented above by an f, indicates which frequency return the depth value applies to. "H" indicates a High frequency depth, and "L" indicates a Low frequency depth.

All Data Output String (90 ASCII Characters)

```
;FDDDDD.DUN@MM/DD/YY,HH:MM:SS.SS PWX PFX SFX PLX MOX SBX POX TXX
TRX GMX SSSS DD.D -BB.B<CR><LF>
```

```
;          start of string character
F          valid digitized bottom flag
           I=invalid or lost bottom
           V=valid digitized bottom
DDDDD.D    digitized depth in selected units
           5 significant digits to the left of the fixed decimal
           point and 1 digit to the right
UN         units in feet(FT),meters(ME),or fathoms(FA)
@         date tag delimiter
MM/DD/YY   date in month/day/year format
,         time tag delimiter
```

HH:MM:SS.SS time in hour/minute/second format

space delimiter

```
PWX       transmit pulse window type
X=1 Rectangular
X=2 Hamming
X=3 Cosine
X=4 Blackman
```

space delimiter

```
PFX       primary transmit frequency
           X=1 3.5 KHz
           X=2 12.0 KHz
           x=3 16.0 KHz or 18 KHz (system dependent)
           x=4 33.0 KHz or 34 KHz (system dependent)
           x=5 Dual Channel LO/HI
```

space delimiter

Operations and Maintenance Manual

SFX synchronization source
 X=1 Internal
 X=2 External

space delimiter

PLX transmit pulse length
 transmit mode=CW
 X=1 200 usec
 X=2 500 usec
 X=3 1 msec
 X=4 2 msec
 X=5 5 msec
 X=6 10 msec
 X=7 25 msec
 transmit mode=FM
 X=1 5 msec
 X=2 10 msec
 X=3 25 msec
 X=4 50 msec

space delimiter

MOX system operating mode
 X=1 CW parametric
 X=2 CW
 X=3 FM parametric
 X=4 FM

space delimiter

SBX frequency sweep bandwidth
 X=1 1 Khz
 X=2 2 Khz
 X=3 4 Khz

space delimiter

POX transmit power level
 X=0 0 dB X=4 -24 dB X=8 OFF
 X=1 -6 dB X=5 -30 dB
 X=2 -12 dB X=6 -36 dB
 X=3 -18 dB X=7 -42 dB

Software Protocol (Cont.)

space delimiter

TXX transmit mode
 X=1 single ping active
 X=2 pinger listen
 X=3 multiping TR
 X=4 multiping TTRR
 X=5 multiping TTTRRR
 X=6 multiping TTTTRRRR
 X=7 multiping TTTTTRRRRR

space delimiter

TRX transmit rate
 X=3 4 Hz
 X=4 2 Hz
 X=5 1 Hz
 X=6 .5 Hz
 X=7 .33 Hz
 X=8 .25 Hz
 X=9 .20 Hz
 X=: .10 Hz
 X=; .05 Hz

space delimiter

GMX system gain mode
 X=0 hydrographic AGC
 X=1 thru 9 hydrographic +3dB thru +27dB manual
 X=ASCII A thru D hydrographic +30 thru + 60 dB manual
 X=ASCII E thru K sub-bottom 1 thru sub-bottom 7

space delimiter

SSSS speed of sound in selected units

space delimiter

DD.D draft setting in selected units to nearest tenth

Operations and Maintenance Manual

space delimiter
Software Protocol (Cont.)

-BB.B background noise level in fixed point referenced to dB/V
<CR><LF> end of string sequence carriage return/line feed

Software Protocol for Dual Channel Echosounders

Depth Only Output String (60 ASCII Characters)

```
;FDDDDD.DUNEEE.E,FDDDDD.D,EEE.E,SHHHH@MM/DD/YY,HH:MM:SS.SS<CR><LF>
```

```
>
```

;

F valid digitized bottom flag for LOW FREQ channel
I=invalid or lost bottom
V=valid digitized bottom

DDDDD.D digitized depth in selected units for LOW FREQ channel
5 significant digits to the left of the fixed decimal point and 1 digit to the right

UN units in feet(FT),meters(ME),or fathoms(FA)

EEE.E echo strength value in dBs for LOW FREQ channel

,

F valid digitized bottom flag for HIGH FREQ channel
I=invalid or lost bottom
V=valid digitized bottom

DDDDD.D digitized depth in selected units for HIGH FREQ channel 5 significant digits to the left of the fixed decimal point and 1 digit to the right

,

EEE.E echo strength value in dBs for HIGH FREQ channel

,

S heave data sign (" " for + heave, "-" for - heave)

HHHH heave data in centimeters

@ date tag delimiter

MM/DD/YY date in month/day/year format

,

HH:MM:SS.SS time in hours/minutes/seconds/hundreths format

<CR><LF> end of string sequence carriage return/line feed

All Data ASCII Output String (115 ASCII Characters)

```

;FDDDDD.DUNEEE.E,FDDDDD.D,EEE.E,SHHHH@MM/DD/YY,HH:MM:SS.SS
PWX PFX SFX PLX MOX SBX POX TXX TRX GMX SSSS DD.D -BB.B<CR><LF>
;
F          start of string character
F          valid digitized bottom flag for LOW FREQ channel
           I=invalid or lost bottom
           V=valid digitized bottom
DDDDD.D   digitized depth in selected units for LOW FREQ channel 5 significant digits
           to the left of the fixed decimal point and 1 digit to the right
UN        units in feet(FT),meters(ME),
EEE.E     echo strength value in dBs for LOW FREQ channel
,         high freq channel data delimiter
F          valid digitized bottom flag for HIGH FREQ channel
           I=invalid or lost bottom
           V=valid digitized bottom
DDDDD.D   digitized depth in selected units for HIGH FREQ channel 5 significant
           digits to the left of the fixed decimal point and 1 digit to the right
,         data delimiter
EEE.E     echo strength value in dBs for HIGH FREQ channel
,         heave data delimiter
S         heave data sign (" " for + heave, "-" for - heave)
HHHH     heave data in centimeters
@        date tag delimiter
MM/DD/YY date in month/day/year format
,         time tag delimiter
HH:MM:SS.SS time in hours/minutes/seconds/hundreths format
           space delimiter

PWX      transmit pulse window type
           X=1 Rectangular
           X=2 Hamming
           X=3 Cosine
           X=4 Blackman

           space delimiter

PFX      primary transmit frequency
           X=1 3.5 KHz
           X=2 12.0 KHz
           x=3 16.0 KHz or 18 KHz (system dependent)
           x=4 33.0 KHz or 34 KHz (system dependent)
           x=5 Dual Channel LO/Hi

```

**Operations
and
Maintenance Manual**

Software Protocol for Dual Channel Echosounders (Cont.)

space delimiter

SFX synchronization source
 X=1 Internal
 X=2 External

space delimiter

PLX transmit pulse length

 transmit mode=CW
 X=1 200 usec
 X=2 500 usec
 X=3 1 msec
 X=4 2 msec
 X=5 5 msec
 X=6 10 msec
 X=7 25 msec

 transmit mode=FM
 X=1 5 msec
 X=2 10 msec
 X=3 25 msec
 X=4 50 msec

space delimiter

MOX system operating mode
 X=1 CW parametric
 X=2 CW
 X=3 FM parametric
 X=4 FM

space delimiter

SBX frequency sweep bandwidth
 X=1 1 Khz
 X=2 2 Khz
 X=3 5 Khz

space delimiter

Software Protocol for Dual Channel Echosounders (cont.)

POX transmit power level
 X=0 0 dB X=4 -24 dB X=8 OFF
 X=1 -6 dB X=5 -30 dB
 X=2 -12 dB X=6 -36 dB
 X=3 -18 dB X=7 -42 dB

space delimiter

TXX transmit mode
 X=1 single ping active
 X=2 pinger listen
 X=3 multiping TR
 X=4 multiping TTRR
 X=5 multiping TTTRRR
 X=6 multiping TTTTRRRR
 X=7 multiping TTTTTRRRRR

space delimiter

TRX transmit rate
 X=3 4 Hz
 X=4 2 Hz
 X=5 1 Hz
 X=6 .5 Hz
 X=7 .33 Hz
 X=8 .25 Hz
 X=9 .20 Hz
 X=: .10 Hz
 X=; .05 Hz

space delimiter

GMX system gain mode
 X=0 hydrographic AGC
 X=1 thru 9 hydrographic +3dB thru +27dB manual
 X=ASCII A thru D hydrographic +30 thru + 60 dB manual
 X=ASCII E thru K sub-bottom 1 thru sub-bottom 7

space delimiter

**Operations
and
Maintenance Manual**

Software Protocol for Dual Channel Echosounders (cont.)

SSSS speed of sound in selected units

 space delimiter

DD.D draft setting in selected units to nearest tenth

 space delimiter

-BB.B background noise level in fixed point referenced to dB/V

<CR><LF> end of string sequence carriage return/line feed

5.0 Equipment Specifications

The following paragraphs will address the BATHY-2010 equipment design specifications and operating characteristics.

5.1 Specifications

5.1.1 Bathy 2010 Specifications

Units	Feet or Meters
Depth Ranges	30, 60, 120, 240, 480, 800, 1500, 2400, 3000, 6000, 15000, 30000 Feet 10, 20, 40, 80, 150, 300, 500, 750, 1000, 2000, 5000, 12000 Meters
Shift Range	0-450 Feet in 1 Foot increments 0-150 Meters in 1 Meter increments
Zoom Range	15, 30, 60, 120, 240, 480, 960, 1920 Feet ; 5, 10, 20, 40, 80, 160, 320, 640 Meters
Zoom Modes	Bottom Zoom, Bottom Lock Zoom, Marker Zoom, GUI Zoom (Playback Only)
Display	Normal Data, Zoom Data, Navigation, Depth, Command/Status, Color Control for Data: 4 Selections or Custom (User Input), Data Color Invert possible
Strata Resolution	Up to 6 cm with 200 Meters of bottom penetration (frequency & bottom type dependant)
Depth Resolution	0.1 Feet, 0.1 Meters
Depth Accuracy	±10 cm to 100 m, ± 0.3% to 12,000 m
Speed of Sound	User Selectable 1400-1600 Meters/Second, 4590-5250 Feet/Second
Navigation Input	NMEA 0183, GLL, GGA, RMC, VTG, VHW, HDT Selectable Baud Rates (RS-232): 4800, 9600, 19200, 38400
Depth/Nav Output	NMEA 0183, DPT, DBT, PMC, ODEC, and ODC Selectable Baud Rates (RS-232): 4800, 9600, 19200, 38400
Printer Output	Centronics (Parallel Port) interface to TDU and EPC Series Thermal Printers
Shallow Water Operation	< 10 Meters; bottom type dependant
Transmit Rate	Up to 4 Hz, depth and operator mode dependant
Event Marks	Periodic, External, and/or Manual (Periodic selectable in 1 minute intervals)
Data File Output	Stores Depth, Navigation, and Graphic Data in ODC format (Proprietary) and Standard SEG-Y. ODC Normal and Zoom Data stored is Pixel data and can be played back and/or printed. It also can be converted to SEG-Y via the ODC to SEG-Y Convert utility.
Data File Playback	Files can be played back and/or printed at Normal or Fast-Forward speed, with Pause and GUI Zoom and a Playback Scroll Bar for ease of file playback.
Frequency Output	3.5 or 12 KHz Nominal (other frequencies available upon request)
Transmit Output Power	2KW, 5KW or 10KW (Pulsed) for LPT-2, LPT- 5 or LPT-10 Power Amplifier
Input Power	B2010 Server – 115 or 230 VAC (Auto Detect), < 100 W B2010 LCD/Keyboard - 115 or 230 VAC (Auto Detect), < 50 W B2010 Sonar Processor and LPT-2 – 115 or 230 VAC (Switch Selectable), < 500 W
Dimensions & Weight	B2010 Server – 2U, 3.5”H x 19”W x 18.75”D, 35 lbs (16 kg) B2010 LCD/Keyboard – 1U, 1.75”H x 19”W x 20.25”D, 28 lbs (13 kg) B2010 Sonar Processor – 3U, 5.25”H x 19”W x 19”D, 27 lbs (12 kg)
Environmental	0 to 50 degrees C Operating Temperature, 0 to 95% Humidity (non-condensing)

Operations
and
Maintenance Manual

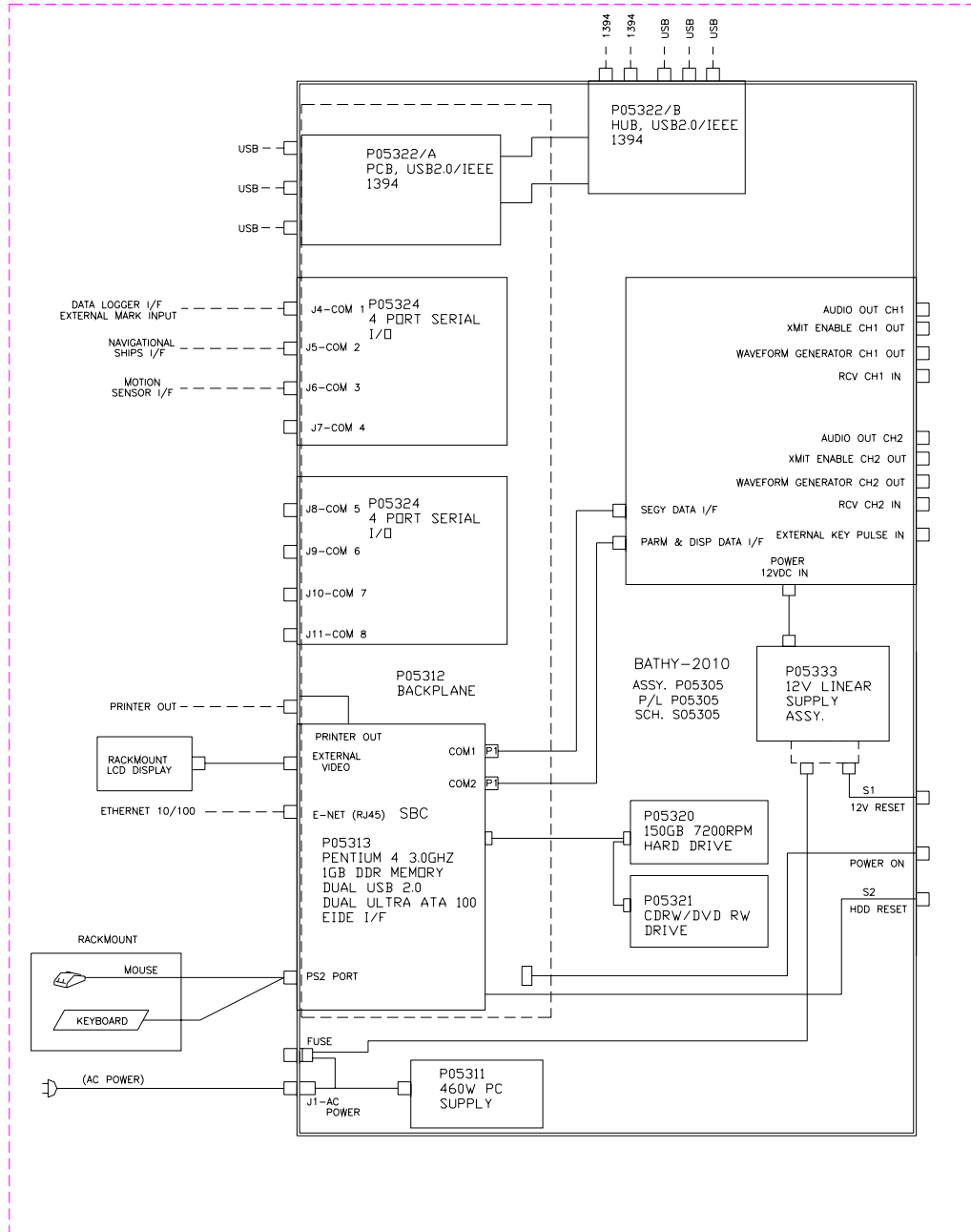

Figure 5-1
Bathy 2010 DESIGN ARCHITECTURE

5.2 LPT 2 Specifications (Refer to Figure 5-2)

Amplifier Type	Pulse Width Modulation (Class D)
Efficiency	Greater than 80% @ maximum power output
Output Power	LPT-2 – 2 KW LPT-5 – 5 KW LPT-10 – 10 KW
Output Impedance	25 to 200 ohms (via MultiTap Output Transformer Frequency and Application dependent)
Load Power Factor	0 to 100% Inductive or Capacitive
Duty Cycle	20% at Max Power
Pulse Length	200usec – 1 sec at Max Power
Dynamic Range	Greater than 70dB
Linearity	< 1%
Total Harmonic Distortion	1% Maximum
Frequency Range	1KHz – 50KHz (3dB point)
RMS Output Noise	-60dB during Transmit, -120dB when disabled relative to Max Power output
Input Signal Scaling	5Vrms Differential for Max Power output
Input Impedance	10K ohms
Voltage Monitor	10 mV/V Differential (LPT-5 & LPT-10 only)
Current Monitor	100 mV/A Differential (LPT-5 & LPT-10 only)
Input Power	LPT-2 – 115 or 230 VAC (Switch Selectable), < 500 W LPT-5 - 208, 220, 240 VAC (Terminal Block), < 2500 W (inrush to 30A) LPT-10 – 208, 220, 240 VAC (Terminal Block), < 3500 W (inrush to 30A)
Dimensions & Weight	LPT-2 –7.00”H x 19”W x 22.00”D, 54 lbs (25 kg) LPT-5 - 15.75”H x 19”W x 27.75”D, 140 lbs (64 kg) LPT-10 15.75”H x 19”W x 27.75”D, 150 lbs (68 kg)
Environmental	0 to 50 degrees C Operating Temperature, 0 to 95% Humidity (non-condensing)

Operations
and
Maintenance Manual

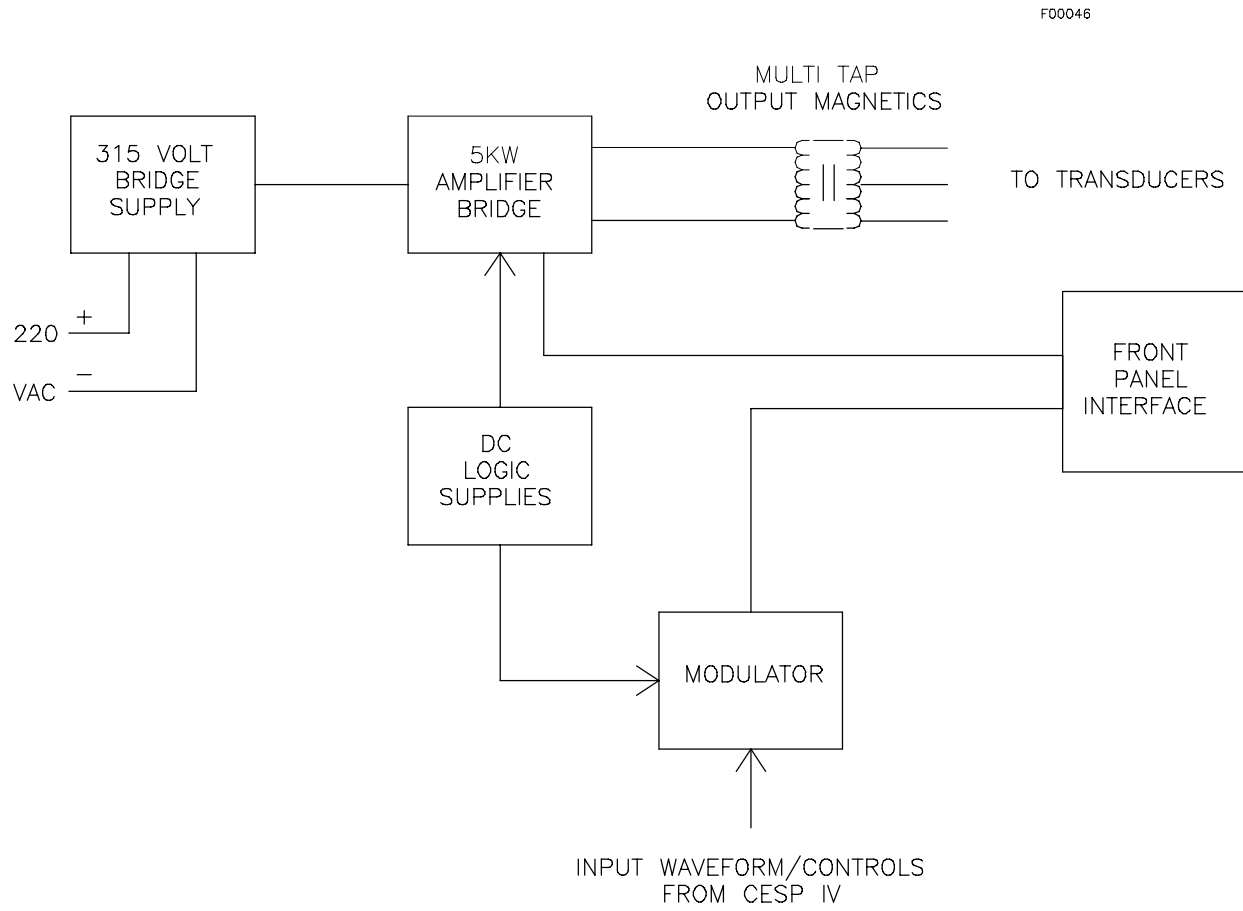

Figure 5-2
LPT MODULAR DESIGN ARCHITECTURE

6.0 Theory of Operation

The BATHY-2010 system is configured as a flexible acoustic measurement sensor device capable of both shallow/deep water hydrographic and sub-bottom profiling applications. Each of these applications depend on certain characteristics in order to perform accurately and reliably. For hydrographic applications, the BATHY-2010 is capable of providing sophisticated algorithms for peak signal detection, automatic modes of: receiver gain, bottom tracking, pulse length and power level controls greatly reduce the probability of inaccurate bottom detection/tracking. For sub-bottom profiling applications the BATHY-2010 is capable of providing high energy/wide bandwidth transmit waveforms and an advanced bottom triggered TVG processing algorithm to facilitate both maximum bottom penetration along with high resolution layer definition.

6.1 Hydrographic Data Processing

The BATHY-2010 receiver electronics operate under microprocessor control and have the following salient characteristics:

- +26 dB Pre-Amp Gain
- 5 Khz Signal Processing Bandwidth
- 60 dB Controlled AGC
- Programmable Balanced Modulator
- 24 Bit Analog to Digital Conversion
- 144 dB Signal Processing Dynamic Range

The output of the receiver is processed by two advanced TI Digital Signal Processors. They implement square law detection processing followed by post-detection matched filters which are set according to transmit pulse length. The HYDROGRAPHIC system gain mode applies peak detection normalization as follows:

- The system calculates an average peak signal value for a 4 ping cycle integration period. The average peak signal value is calculated utilizing a sliding integration window which is 2 times the transmitted pulse length in value. The average peak value is then used to normalize the detected signal by applying a gain factor which is proportional to the maximum signal level (gain factor=max value/average peak value). This is done dynamically for each processed output sample.

Operations and Maintenance Manual

The Bathy 2010 then performs bottom detection/tracking functions. The bottom detection predictive filter algorithm uses ships speed, detection threshold and fully automatic operation to provide reliable "hands off" digital depth data under the majority of operating conditions. This is facilitated by offering automatic modes of pulse length and power level control. The peak detection mode of bottom digitizing provides the most accurate representation of the mid-point of the acoustic beam and serves as a method of increasing the accuracy of a wide acoustic beam system. Sub-Bottom Profiling Data Processing

The BATHY-2010 system incorporates FM wide bandwidth signal processing (CHIRP) to provide penetration and resolution for sub-bottom profiling applications. The system employs a matched replica correlation algorithm with normalization to obtain the raw sub-bottom data. A user selectable bottom-triggered time varied gain (BT-TVG) is then applied to offset sediment attenuation resulting in optimum highlighting of deep sub-bottom layers. The BATHY-2010 typically is operated at a center frequency of 3.5 KHz with a swept FM signal, which can be programmed up to a 8KHz frequency sweep. The maximum sweep should always be used as it results in the finest resolution and highest SNR. In sub-bottom mode the output of the receiver is processed by 2 TI Digital Signal Processors. They implement the correlation detection (matched replica filter) processing. Filter replica coefficients are calculated by transmitting a waveform into the receiver electronics. The SUB-BOTTOM system gain mode applies a BT-TVG to the raw data in .5dB/m steps from 0.0 - 4.0dB/m and should be applied as follows.

- The amount of BT-TVG gain applied should be inversely proportional to the sediment attenuation characteristics. This produces an effect that causes an embedded layer in the sub-bottom that is harder or softer than the surrounding sediment to be highlighted. The harder the bottom, the greater the echo attenuation as it travels thru bottom layers, and consequently the greater the applied gain factor shall be. As in HYDROGRAPHIC mode of operation, the hardware receiver gain is controlled as a function of ambient RMS background noise levels.

6.2 Pinger Mode Theory of Operation

Pinger Mode is provided to track object depths in the water column by receiving unsynchronized transmit pings of known frequency and pulse width at a given transmit rate. The asynchronous nature of the pinger and the fixed ping rate make the evaluation of pinger echo returns difficult under certain pinger and bottom depth conditions. The operating mode is briefly described below.

In this mode the direct and bottom returns simply mirror each other with the direct return reflecting the pinger path through the water column. When the pinger is descending the descending return reflects the direct path and vice-versa on pinger ascent. Each crossing reflects a 1 second boundary in time or 2400 feet (750m) in depth assuming a nominal sound velocity of 4800 ft/sec (1500m/sec). Once the final crossing has been logged the pinger is less than 2400 feet from the bottom. Thus, the operator should monitor the returns and pinger descent speed to insure the desired results are accomplished. Listed below is a detailed step-by-step procedure for determining pinger location:

PASSIVE PINGER MODE- Listen Only Mode Procedure:

1. Verify that the BATHY-2010 system is digitizing on a valid bottom by observing the "DEPTH" parameter in the lower left portion of the display (Transmit Mode = CW Frequency 12kHz). Note that the pinger should not be pinging during this step as it will cause problems with the depth digitizing process.
2. Record the Bottom Depth and calculate the number of crossings as follows:
integer [Bottom Depth/1200ft(or 750m)]. Where integer [x] is truncate
(i.e. 1.7=1, 1.3=1, .99=0).
3. Select Listen only by selecting under the View Menu "Passive Pinger".
4. Select the appropriate pulse length to match the BATHY-2010 system to the pinger's transmit pulse length. Valid pulsewidths are: 2msec, 5msec, and 10msec.
5. Commence pinging and set the DC GAIN to a gain where both returns are strong and consistent. Note that the pinger direct return may appear stronger than desired but once the pinger depth is greater than 100-150 feet the returns will appear similar in magnitude.
6. Monitor the returns and note each time the returns cross paths.
7. When the calculated numbers of crossings have been noted monitor the returns and insure that they do not cross path again. Crossing again would indicate that the pinger has hit the bottom.

THIS PAGE INTENTIONALLY LEFT BLANK

7.0 Installation

Information on the installation of the BATHY-2010 is detailed in the following sections:

- System Setup
- Environment
- Input Power
- BATHY 2010/BATHY 2010P
- Linear Power Transmitter
- Transducers
- Hardcopy Installation
- Serial Interfaces
- Keyboard
- External Sync
- Linear Power Transmitter
- Storage Device
- Recommended Spares List

The installation wiring diagrams included in this section illustrate all electrical connections to the BATHY-2010 system. Also included are hardware outline drawings illustrating all BATHY-2010 mechanical dimensions and a recommended spares list

The diagrams are listed below:

- BATHY-2010 Top Level Installation Diagram and Parts List (Figure 7-1&
-)
- BATHY-2010 Mechanical Outline Drawing (Figure 7-21)
- BATHY-2010 Cable Drawings (Figure 7-3 through Figure 7-9,
- Transducer Specifications and Junction Box Drawings (Figure 7-10,Figure 7-14,Figure 7-19)
- Sea Chest Assembly Drawing (Figure 7-20)

7.1 System Setup

The BATHY-2010 is a high power, full ocean depth echosounder that is easy to install and operate for the informed end-user. With the emphasis on *informed* it is imperative that the user read over the entire installation section of the manual before starting with the system installation. The user must refer to the BATHY-2010 Top Level Installation Diagram Figure 7-1 for detailed information. For optional items, more detail on individual items is provided in the OPTIONS section. The system may be used in a minimum configuration with only the appropriate transducers, input power, and a keyboard connected. Any combination of the external functions shown in the installation diagram may be used as well.

Operations and Maintenance Manual

7.2 Environment

The BATHY-2010 has an operating temperature range from 0° C to +50° C. It can be stored at temperatures from -25 ° C to +50 ° C. All of the BATHY-2010 units are packaged in ruggedized, rack mount enclosures designed for shipboard use.

7.3 Input Power

The BATHY-2010 requires AC power connection to the LPT, the Server, and the LCD Display. The Sonar unit is powered from the LPT attached via C00184-1 power cable at the rear of the LPT unit. (Figure APPENDIX C - 11.1(B)).

115/220 VAC +/- 10 % (Switch Selectable on LPT rear panel)

50-60Hz

15 Amp Service (Minimum)

All of the 120 VAC power for the rest of the system is generated from the LPT power input. A Power Strip (Figure 7-7) is strapped in the rack for power distribution to the other BATHY-2010 system components. The Bathy 2010 power is connected by plugging the POWER CORD CABLE into the power strip . The Bathy 2010 System Server, LCD Display, and Hardcopy device must be plugged into the Power strip as well. (Refer to Figure 7-1)

7.4 Linear Power Transmitter

The Linear Power Transmitter (LPT) provides the electric output power to the transducers. Connectors J2 (LF Out) and J6 (HF Out) on the LPT rear panel are connected to the appropriate transducers (see Figure 7-1 for customer specific installation information). Connectors J3 (LF Receive) and J4 (HF Receive) are connected to J11 (CH 1 Receive) and J9 (Ch 2 Receive) respectively on the BATHY 2010. These cables (Figure 7-4& Figure 7-6) provide the Control I/O and Receiver input path and must be connected for the system to function properly.

7.5 Transducers

The BATHY-2010 supports SYQWEST, INC.'s entire transducer product line. Specifics of transducer installation depend upon the system frequencies and the transducers selected. The top level installation diagram reflects the user specific transducer interconnect. Transducer specifications are also included at the end of this section. For any further information regarding shipboard transducer installation please refer to the SYQWEST, INC. "Bathymetric Systems Handbook"..

7.6 Hardcopy Installation

The BATHY-2010 system accommodates a multitude of hardcopy devices. The hardcopy device is connected to a standard 25 Pin LPT Port on the rear panel of the Bathy 2010 Server unit. The following information provides all of the configuration and interfacing requirements for each of the hardcopy devices (Figure 7-1).

7.6.1 TDU-850

Configuration DIP Switches - 2,3,8-10 ON, 1,4-7 OFF
 11 ON Plastic Film, 11 OFF Paper
 Printer Cable Connection - 25 pin "D" connector on Server back panel

7.7 Serial Interfaces

There are 4 serial port connections on the rear panel of the BATHY-2010 Server unit. They are 9-pin D connectors labeled COM 1 – COM 4 these provide all the serial input/outputs for: Data Logger output, External Mark input, Navigation input, Motion Sensor input, (heave data). The serial ports provide RS-232 throughput and thus all cable lengths and other interfaces requirements must comply with the RS-232 standard.

P05306 Accessory Kit

<u>PART NO.</u>	<u>DESCRIPTION</u>	<u>QTY</u>
310-001	Fuse, 1A	1 (for Sonar Unit)
313-010	Fuse, 10 Amp	1 (for LPT-5/10 unit)
313-005	Fuse, 5 Amp	1 (for LPT-2 unit)
6282-8SG-522	Conn, 8 Pin ConXall	1 (key pulse connector)
MS3106A-16-10P	Transducer Conn	1 LPT Output
MS3057A-8	Transducer Conn backshell	1 LPT Output
*MS3106A-14-7P	Transducer Conn	1 / (dual channel only)
*MS3057A-6	Transducer Conn backshell	1 / (dual channel only)

Table 7-1
 P/N P05306-x
 BATHY-2010 ACCESSORY KIT

Operations and Maintenance Manual

7.8 Keyboard / Trackball

The user interface to the BATHY-2010 system is a keyboard (Figure 7-1). The keyboard and trackball are standard PC PS/2 type or equivalent type must be used . They are connected to the Y-Cable connected to the SBC on the rear panel of the Bathy 2010 Server unit. The keyboard has to be connected to the BATHY-2010 system for the power -ON initialization sequence to occur properly.

7.9 External Sync

The External Synchronization function is accessed from the rear panel of the Bathy 2010 unit. An 8-pin ConXall connector Labeled J3 provides the single end or differentially driven controls. The signals are described in Section 3.6. The Trigger input is opto-coupled and the Ping Done output is driven with an RS-422 driver.

NOTES:

- 1) LPT IS FACTORY SET AT 220VAC SINGLE PHASE.
- 2) DASHED LINES DENOTE OPTIONAL ITEMS, USED HERE FOR REFERENCE ONLY.
- 3) REFERENCE P05300-25 PARTS LIST.

POWER:

- ① AC PWR 110/220VAC 50/60HZ AUTOSENSING
- ② AC PWR 110VAC 50/60HZ
- ③ AC PWR IN 110 / 220 VAC MANUAL SELECT ON LPT-2
- ④ AC PWR IN 110 / 220 VAC MANUAL SELECT ON TDU-850

OPTIONAL

CABLE:

- ① CUSTOMER SUPPLIED

DIMENSIONS:

- Ⓐ LPT-2 AMPLIFIER: 4U 19" RACKMOUNT SPACE, 24" MIN. DEPTH REQ'D.
- Ⓑ SONAR UNIT: 3U 19" RACKMOUNT SPACE, 20" MIN. DEPTH REQ'D.
- Ⓒ SERVER: 2U 19" RACKMOUNT SPACE, 26" MIN. DEPTH REQ'D.
- Ⓓ KEYBOARD UNIT: 1U 19" RACKMOUNT SPACE, 19" MIN. DEPTH REQ'D.
- Ⓔ LCD DISPLAY: 7U 19" RACKMOUNT SPACE, 6" MIN. DEPTH REQ'D.

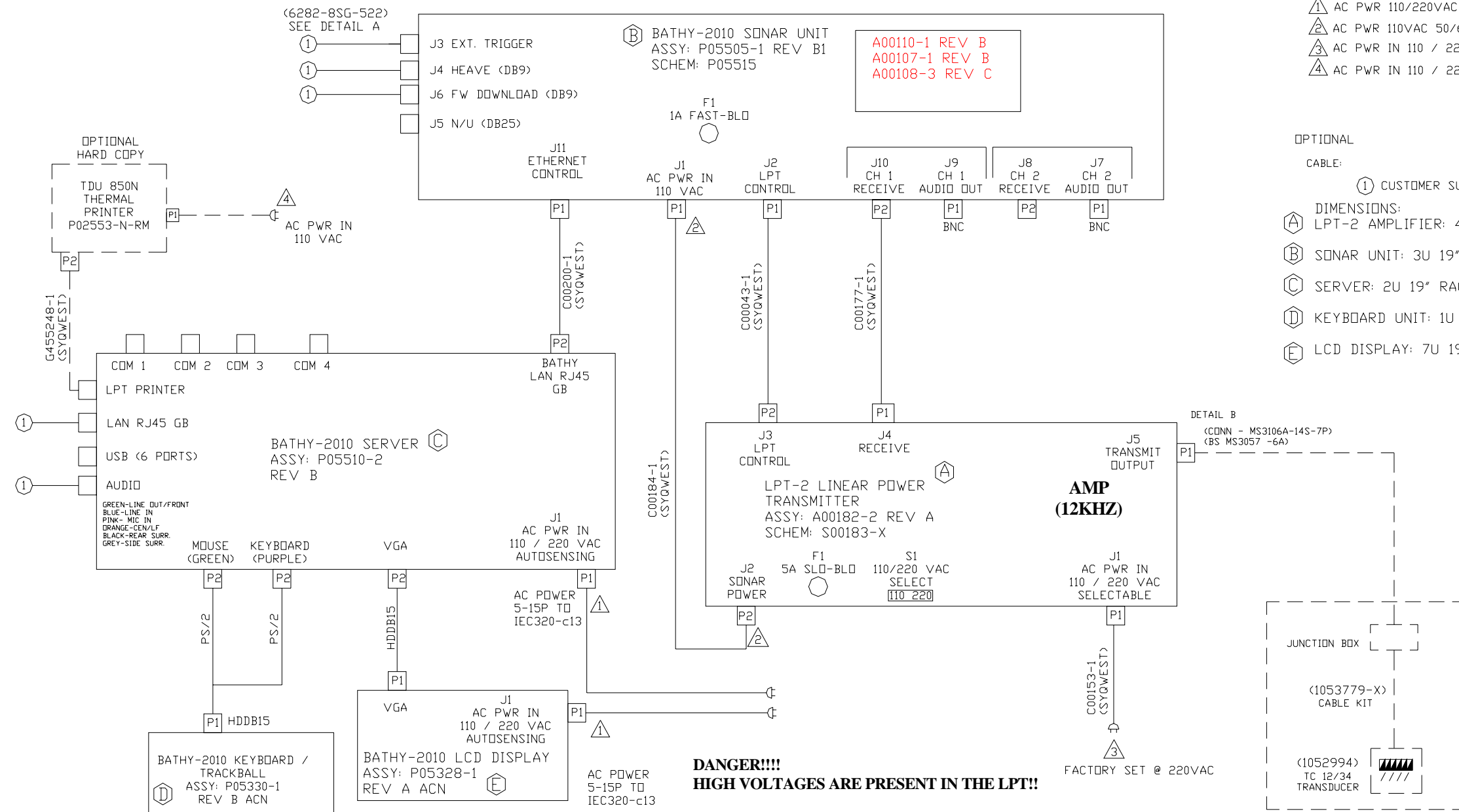

DANGER!!!!
HIGH VOLTAGES ARE PRESENT IN THE LPT!!

ALWAYS DISCONNECT POWER, AND ALLOW TIME TO DISCHARGE BEFORE OPENING COVER OR REMOVING LPA MODULE!

Figure 7-1
BATHY-2010 TOP LEVEL INSTALLATION DIAGRAM
P/N P05300-25 REV A

Operations
and
Maintenance Manual

FIND #	PART #	DESCRIPTION	QTY.
	P05500-24	BATHY-2010 TOP LEVEL	
	P05502-X	BATHY 2010 INTERCONNECT DIAGRAM	1
1.	P05505-1	BATHY-2010 SONAR UNIT	1
2.	A000171-1	LPT-10, 3.5KHZ	1
3.	P05510-2	BATHY-2010 SERVER UNIT	1
4.	P05528-1	RACKMOUNT, 17"LCD	1
5.	P05530-1	RACKMOUNT KEYBD/TRACKBALL	1
6.	973690	TR109 TRANSDUCER, 3.5KHZ	16
7.	P00778-4	JUNCTION BOX, 9 ARRAY	*
8.	P05223-N-RM	TDU-850N THERMAL PRINTER	*
9.	C00200-1	CABLE, SONAR CNTRL, EXT ENET	1
10.	C00184-2	BATHY-2010 SONAR POWER CABLE	1
11.	C00043-1	Bathy 2010/LPT INTERFACE CABLE	1
12.	C00177-1	Bathy 2010/LPT RECEIVER CABLE	1
13.	P05506-x	Accessories Kit	1
14.	P05540	BATHY-2010 GUI (INSTALLED, AND 1 BACK UP CD)	1
15.	P05545	BATHY-2010 OPERATORS MANUAL (1 HARDCOPY, 1 on install CD)	1

* DENOTES OPTIONAL ITEMS
* OPTIONAL ITEMS

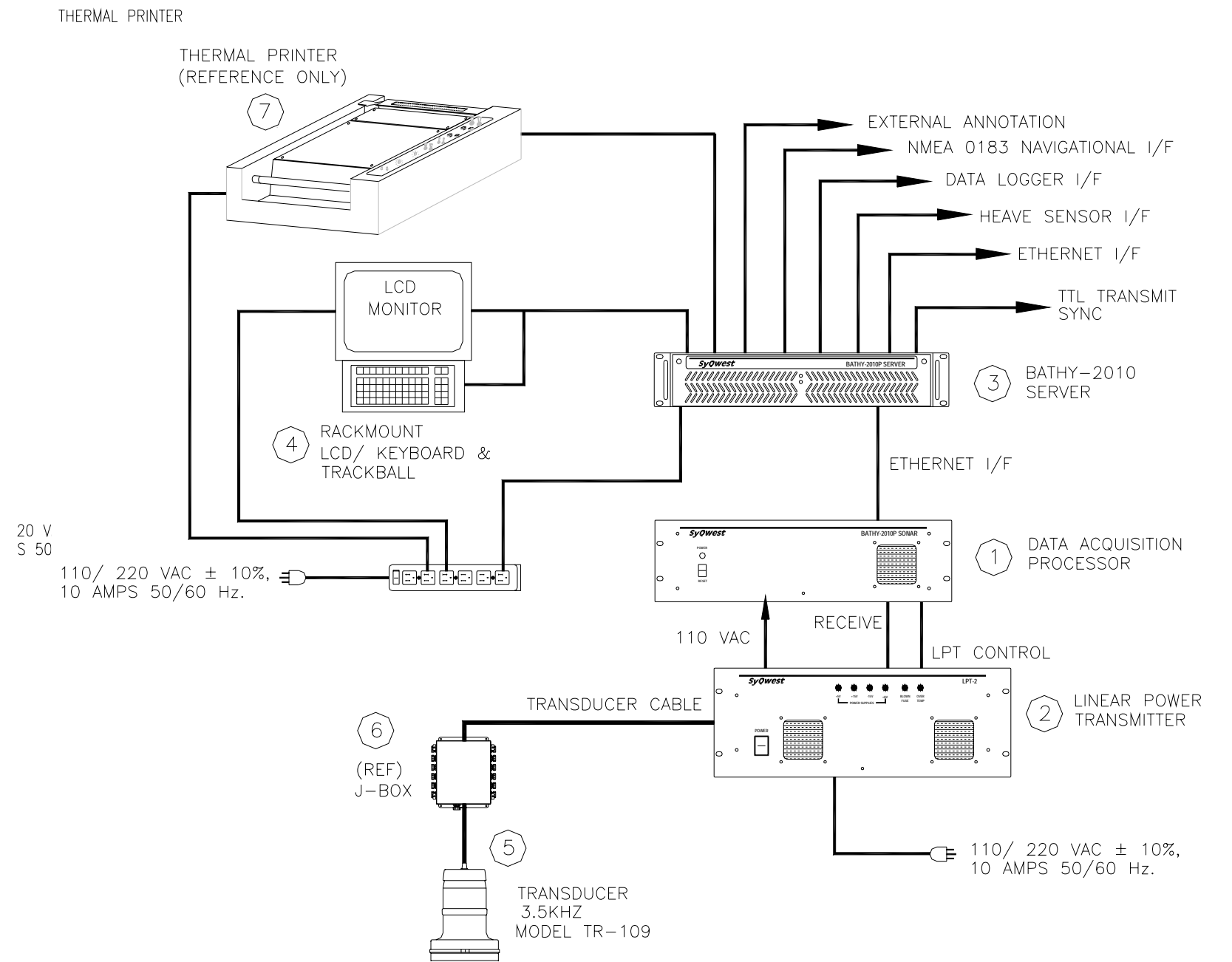

Figure 7-2
BATHY-2010 SUB-BOTTOM SYSTEM TOP LEVEL PARTS LIST
P/N P05500-22

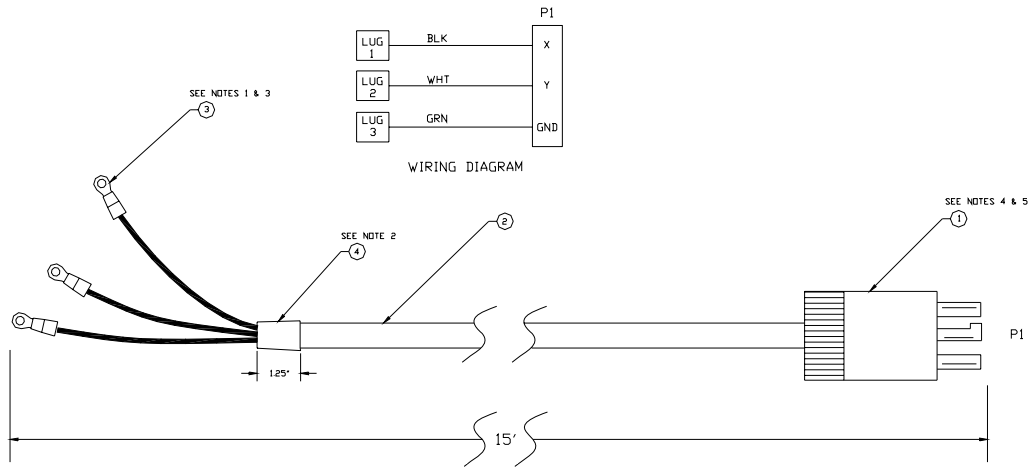

Figure 7-3
LPT-5/10 POWER CABLE P/N C00047-2

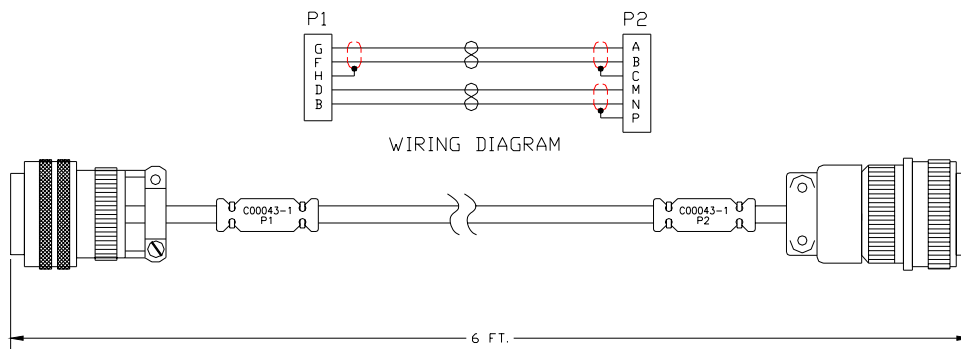

Figure 7-4
LPT I/O INTERFACE CABLE P/N C00043-1

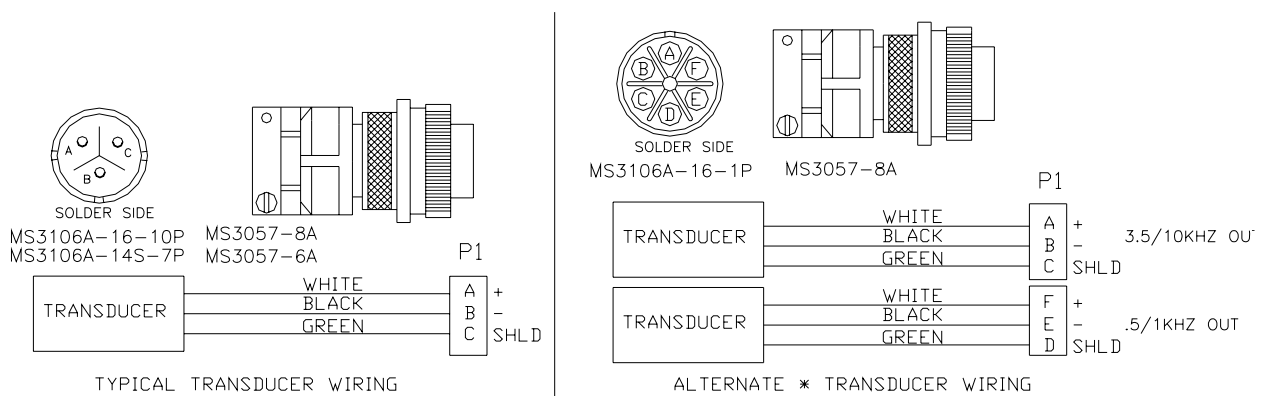
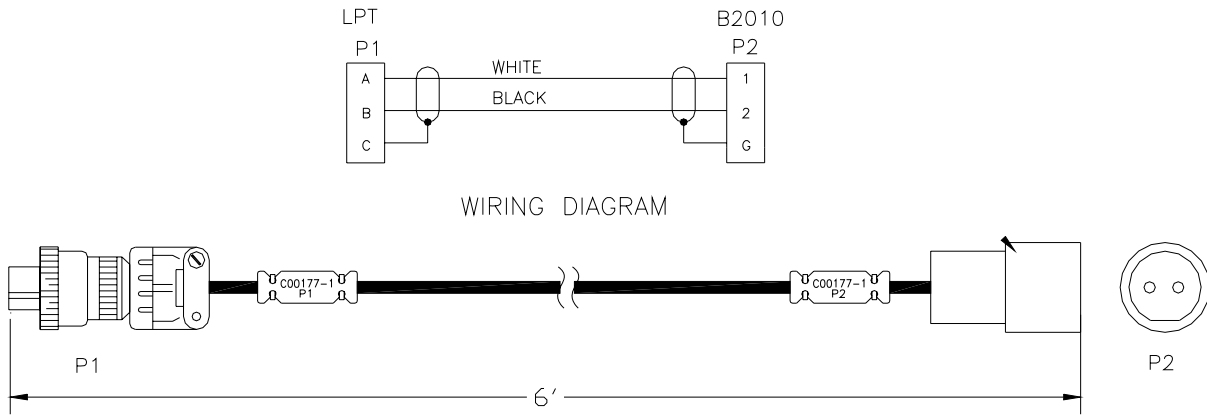
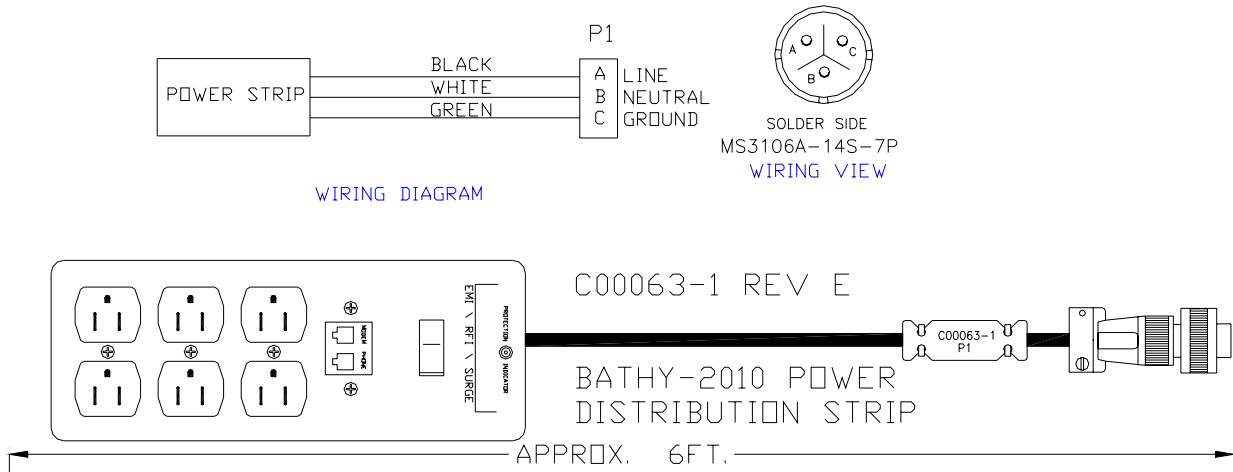

Figure 7-5
TRANSDUCER WIRING, TYPICAL / ALTERNATE

**Operations
and
Maintenance Manual**



**Figure 7-6
B2010 / LPT RECEIVER CABLE
P/N C00177-1**



**Figure 7-7
POWER STRIP CABLE
P/N C00063-1**

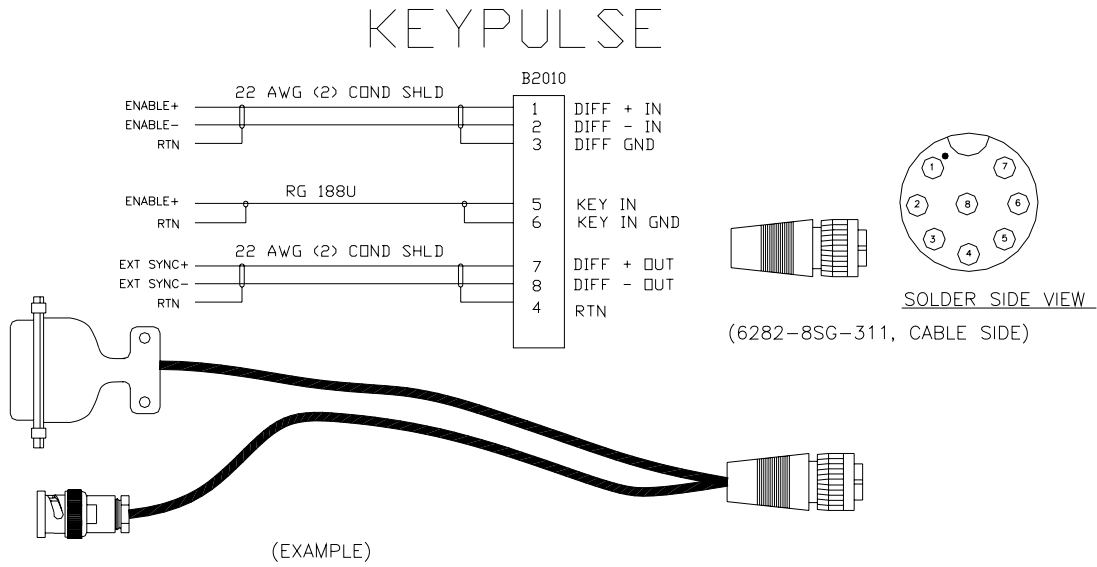

Figure 7-8 EXT SYNC / KEYPULSE WIRING

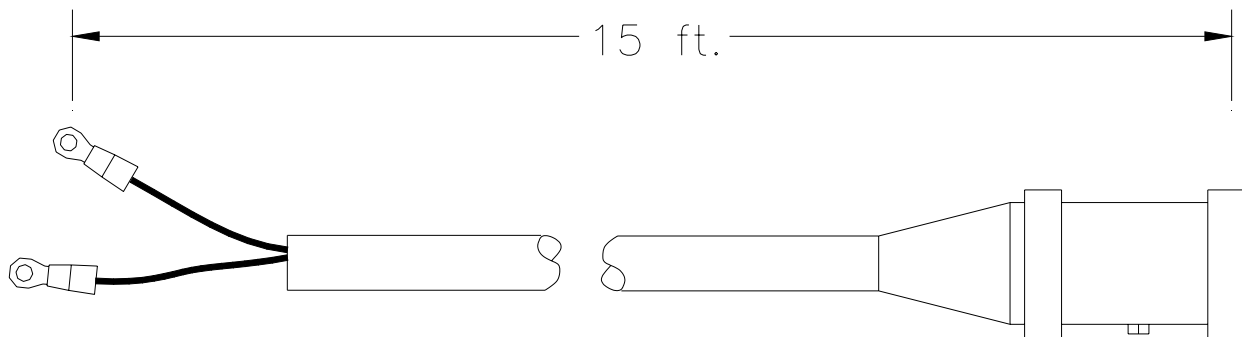
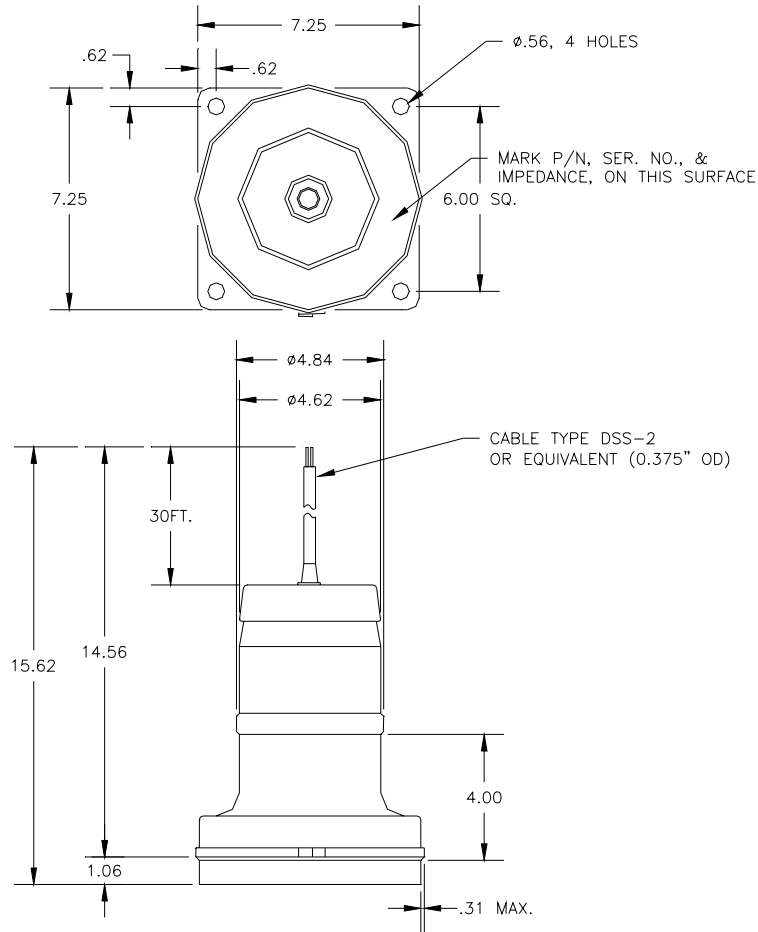

Figure 7-9
CABLE KIT (TR-109) (optional, special order)
P/N 909955-015

**Operations
and
Maintenance Manual**

Model TR-109 – All exposed surfaces molded rubber.



Frequency.....	3.5 KHz
Impedance	125 Ohms
Beam Width	-3dB 31°, -6dB 45°
Receive Sensitivity	-174dB
Pulse Power.....	600 Watts
Transmit Source per volt	+156dBa
Weight	26 lbs
Cable.....	30ft., DSS-2 cable

P/N: 973690 MODEL TR-109 TRANSDUCER

**Figure 7-10
TR-109 TRANSDUCER
P/N 973690-1**

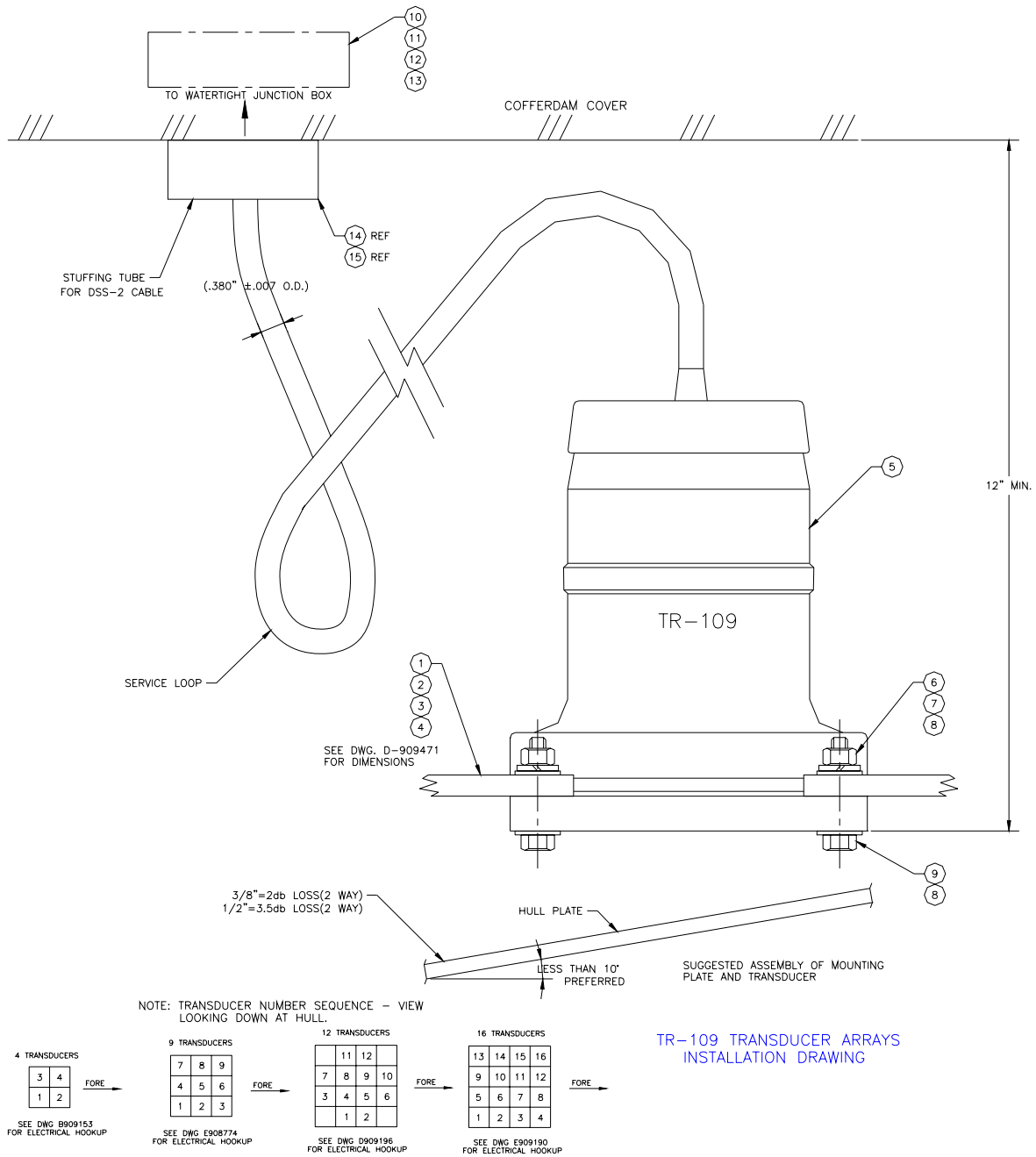
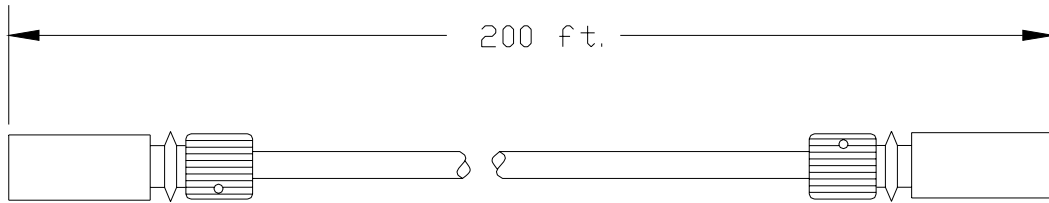

Figure 7-11
TR-109 TRANSDUCER ARRAY INSTALLATION
P/N 869159

**Operations
and
Maintenance Manual**



TC 12/34 Cable Kit, (length specified at time of order)

P/N 1053779-x

Model TC-12/34 - Nickel Aluminum Bronze Housing

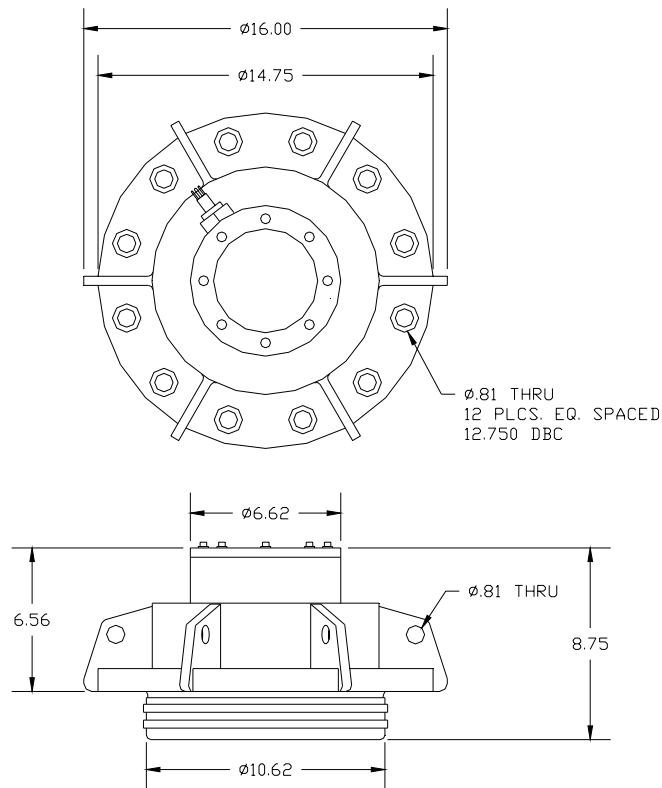

12 KHz	Frequency	34 KHz
200 Ohms	Impedance	200 Ohms
30'	Beam Width	10'
-169dB	Receive Sensitivity	-179dB
2000 Watts	Pulse Power	500 Watts
140 lbs	Weight	140 lbs
100ft or 200ft, FSS-2 cable	Cable	100ft or 200ft, FSS-2 cable

**Figure 7-12
TC-12/34 TRANSDUCER
P/N 1052994**

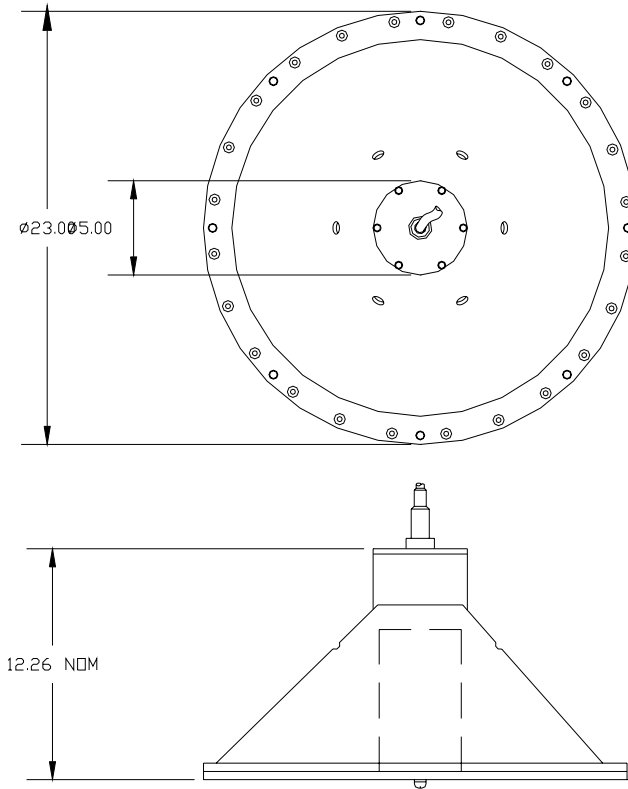

Frequency..... 12 KHz
 Impedance 195 Ohms
 Beam Width 18°
 Receive Sensitivity..... -165dB
 Pulse Power..... 1200 Watts
 Transmit Source 167dB
 Weight 35 lbs
 Cable..... 20M.; DSS-3 cable
 Model TC-12NB - 316 SST housing/PVC Cone.

Figure 7-13
TC-12NB TRANSDUCER
P/N P00363-1

**Operations
and
Maintenance Manual**

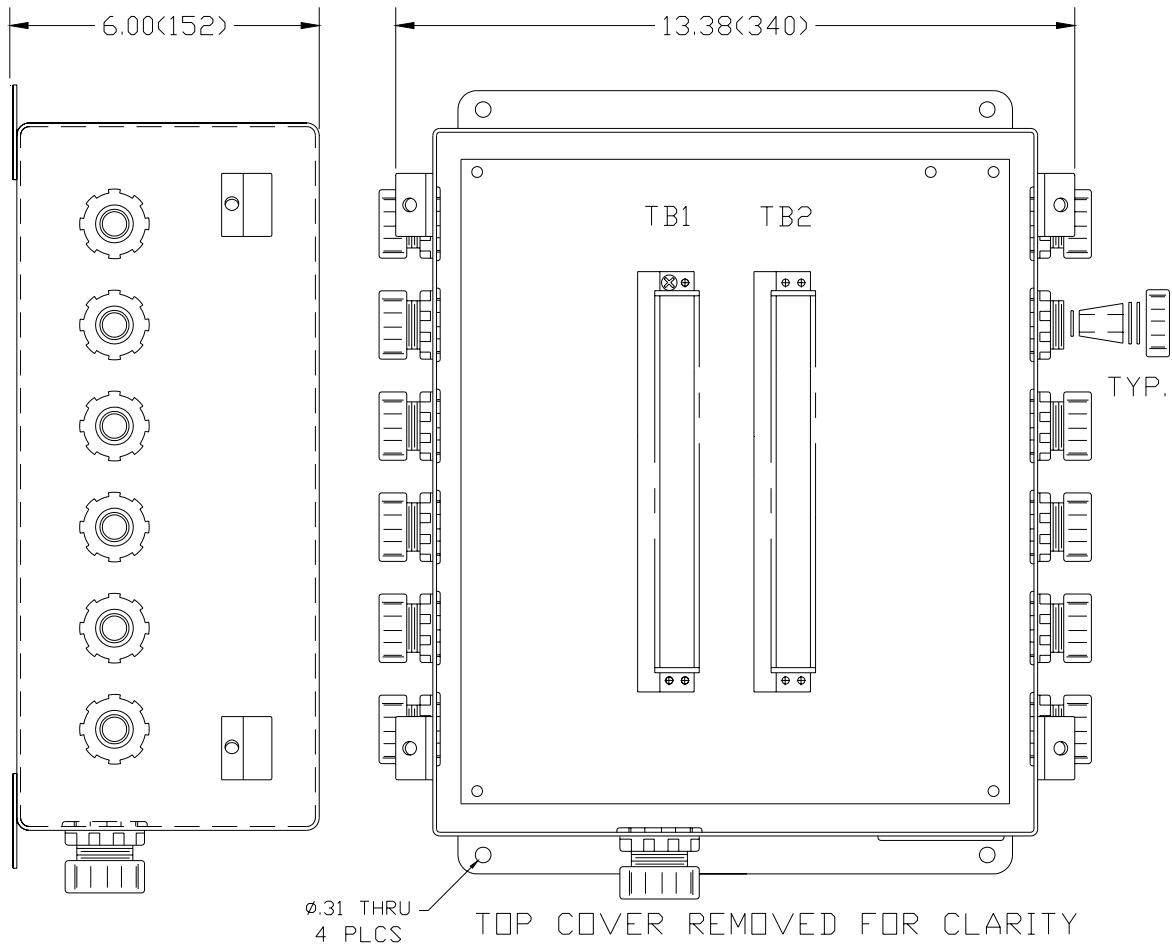

Figure 7-14
JUNCTION BOX ASSEMBLY
P/N P00778-x (ref only)

<u>FIND #</u>	<u>PART #</u>	<u>FCSM</u>	<u>DESCRIPTION</u>	<u>QTY</u>
1	P00777-4	33642	WATERTIGHT JUNCTION BOX	1
2	CJ-20-140	71468	TERMINAL BLOCK	2
3	M19622/3-002	99820	STUFFING TUBE	16
4	MI9622/17-03	99820	NYLON KIT ASSEMBLY	16
5	M19622/3-004	99820	STUFFING TUBE	1
6	MI9622/19-0001	99820	NYLON KIT ASSEMBLY	1
7	DSS-3-100	81349	CABLE	1

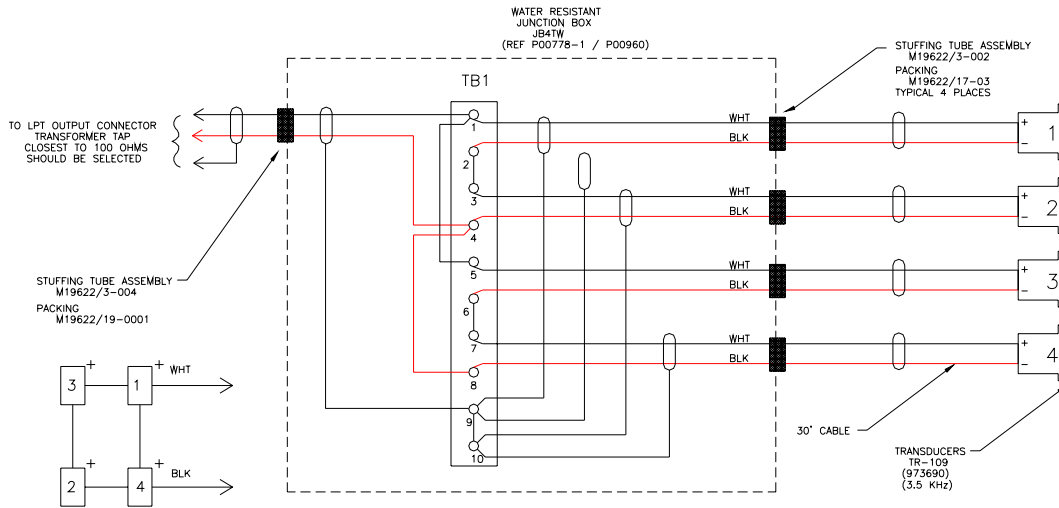

Figure 7-15
4 TR-109 TRANSDUCER ARRAY SCHEMATIC
P/N 909153-1

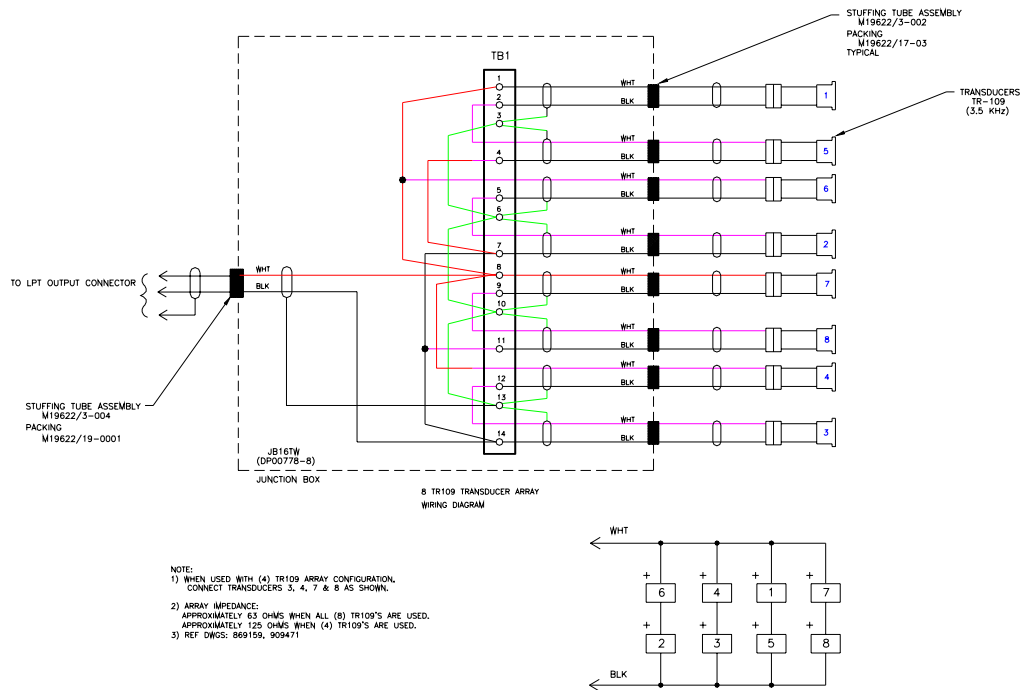

Figure 7-16
4 / 8 TR-109 TRANSDUCER ARRAY SCHEMATIC
P/N P03308-1

Operations
and
Maintenance Manual

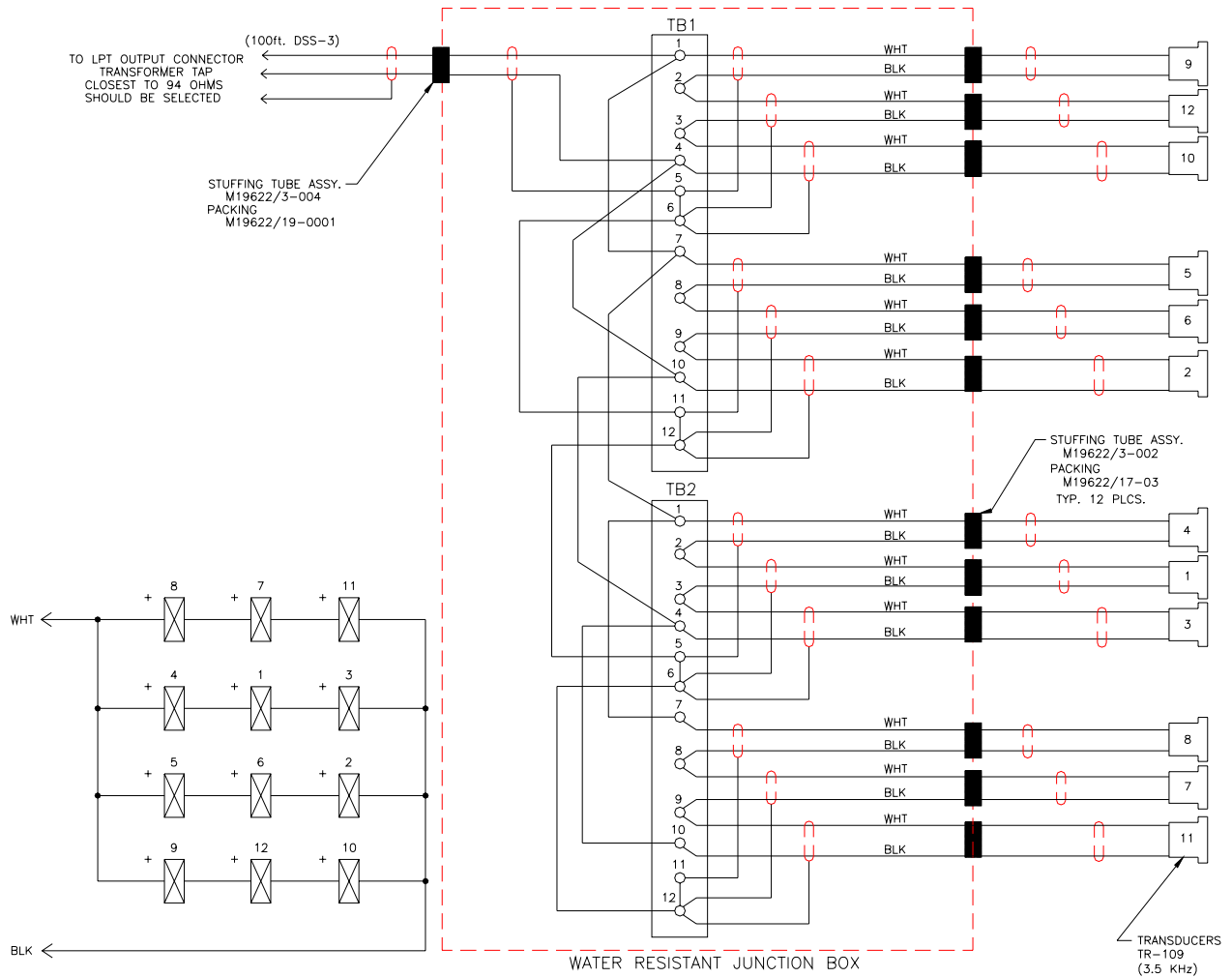

Figure 7-17
12 TR-109 TRANSDUCER 3x4 ARRAY SCHEMATIC
P/N 909196-1

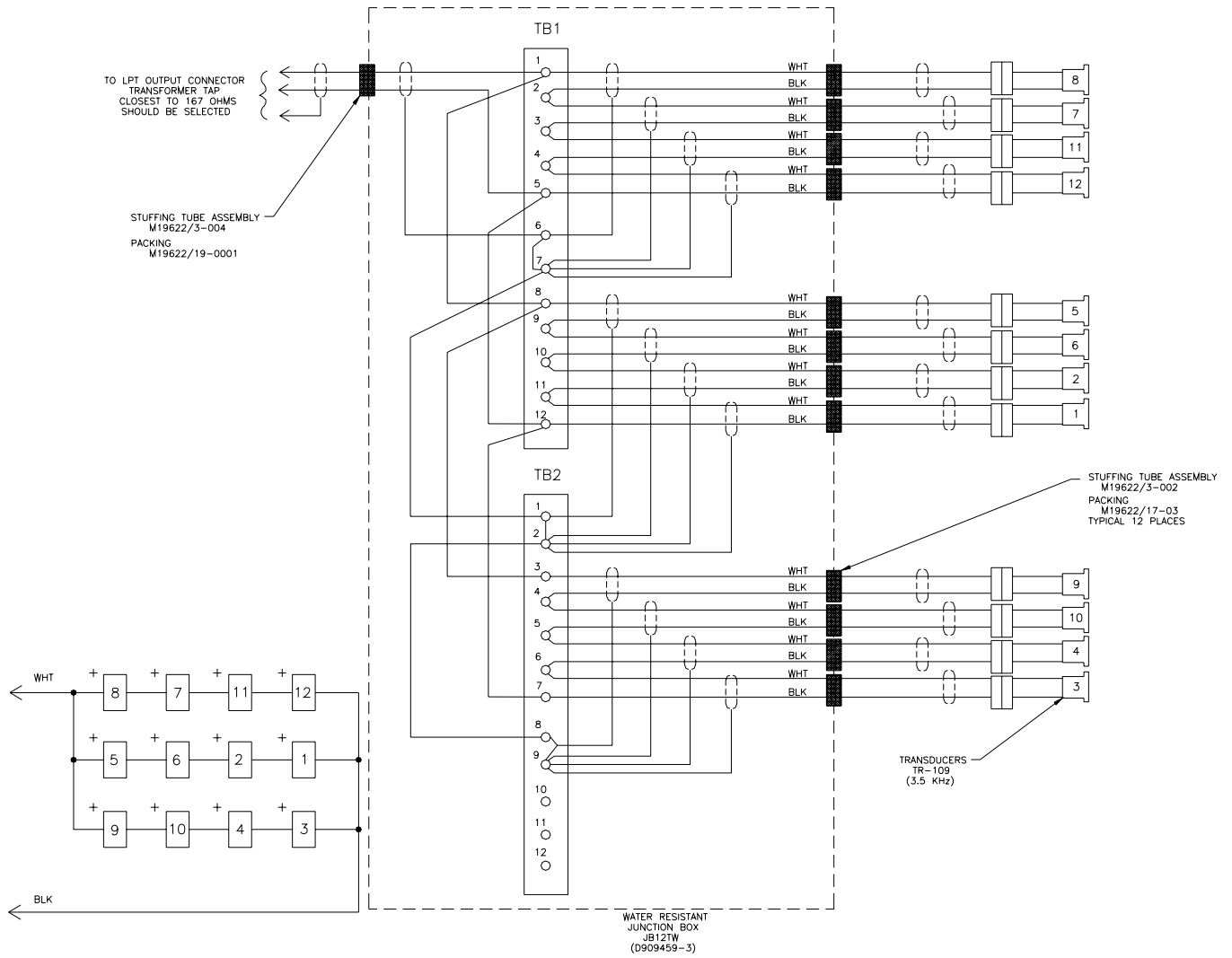

Figure 7-18
12 TR-109 TRANSDUCER 4x3 ARRAY SCHEMATIC
P/N 909196-2

Operations
and
Maintenance Manual

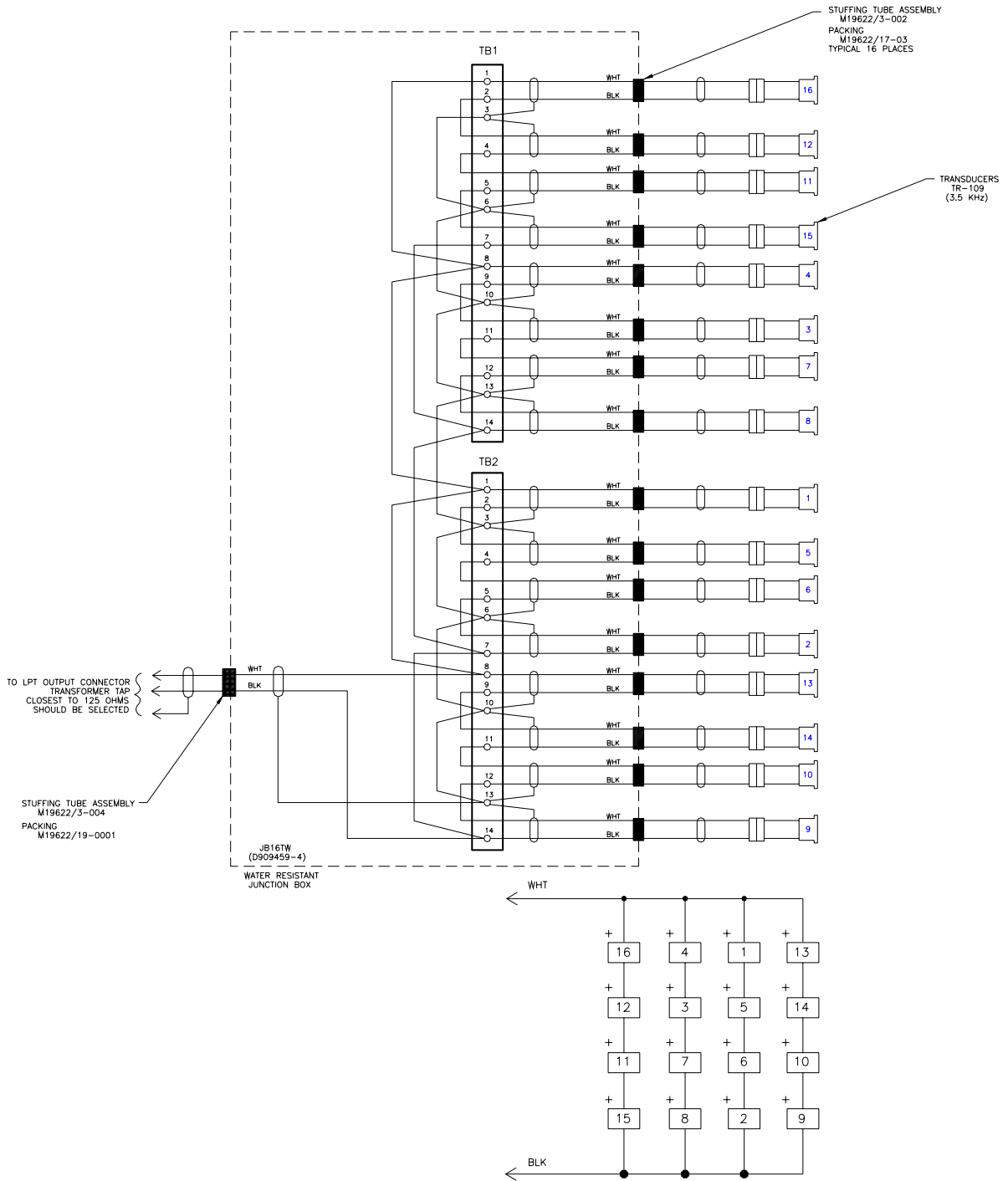

Figure 7-19
16 TR-109 TRANSDUCER ARRAY SCHEMATIC
P/N 909190-1

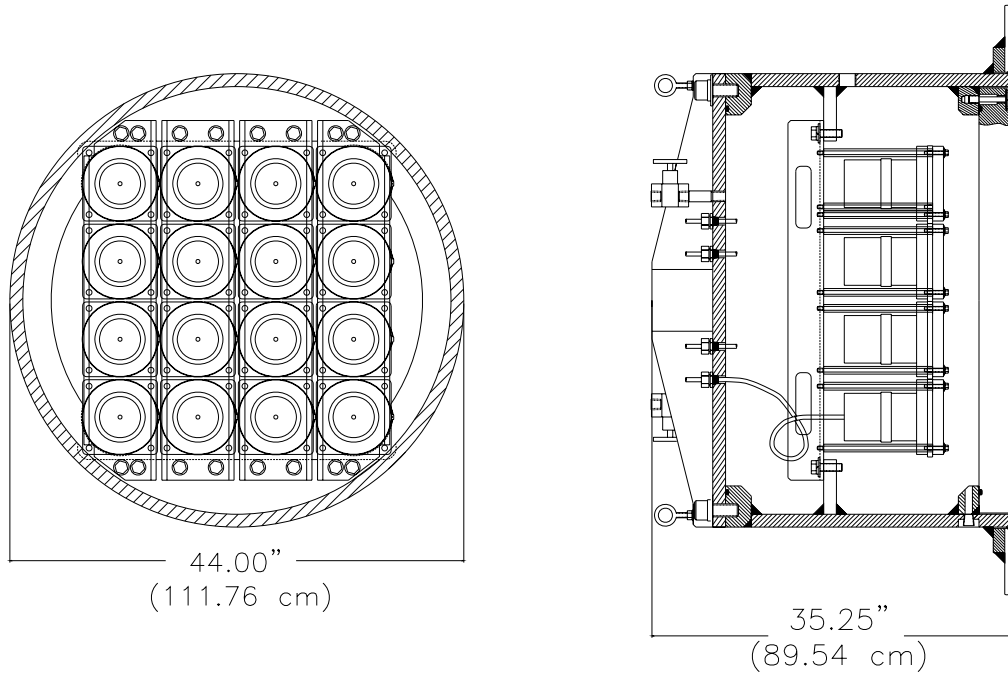

Figure 7-20
SEA CHEST ASSEMBLY
P/N P01511 (reference only)

<u>FIND #</u>	<u>PART #</u>	<u>FCSM</u>	<u>DESCRIPTION</u>	<u>QTY</u>
---------------	---------------	-------------	--------------------	------------

Operations
and
Maintenance Manual

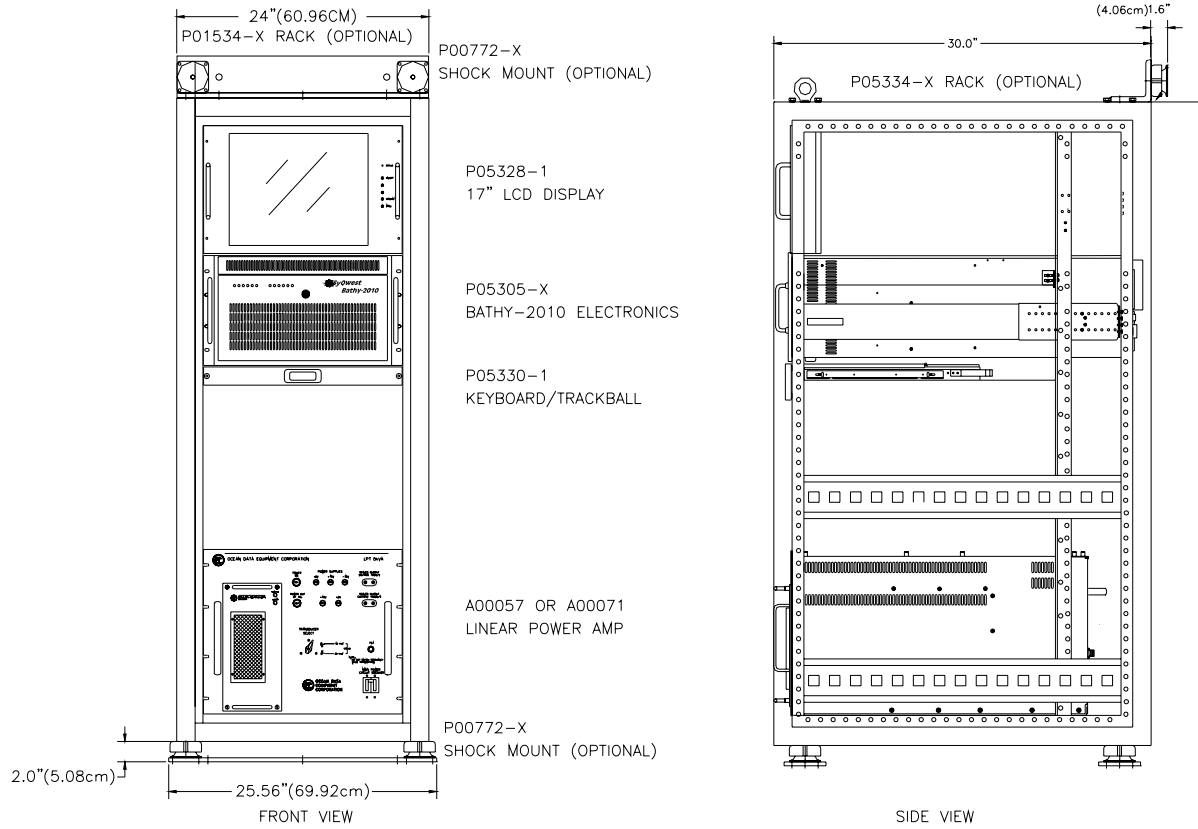

Figure 7-21
RACK OUTLINE AND ASSEMBLY
P/N P05334-X (Optional)

8.0 MAINTENANCE

8.1 POST (Power On Self Test)

Each time power is applied to the Bathy-2010 Sensor, it performs a series of self-tests to ensure that it is working optimally. The tests occur as follows:

- Test 1 – Initialization Test**
Checks overall functionality of the sensor hardware to verify it is operational.
- Test 2 – RAM Test**
Verifies that the system RAM is operational.
- Test 3 – Serial EPROM Test**
Verifies that the Serial EPROM is operational and it's checksum is valid.
- Test 4 – Flash Memory Test**
Verifies that the Flash Memory is working and it's checksum is valid.

If any of the Tests fail, one of the 8 Green LEDs on the DSP CCA will remain illuminated. Note that during POST all 8 of the Green LEDs will flash once to indicate that the associated tests have been run. If one of the LED's remains illuminated, and the blue LED does not flash at a 1Hz rate, the Bathy-2010 Sensor will not be operational and the user should contact SyQwest's Support Dept. for assistance. The Sensor may just need to have its flash reprogrammed but SyQwest should be notified anyway. The Bathy-2010 PC Software will detect a problem with the Sensor as well. The problem will show up on the GUI in the System Status window as a "Sensor State Unknown" or other error condition.

If the Sensor passes these tests, the blue LED on the DSP CCA (visible through slots in top cover of Sensor Unit) will blink at 1 Hz indicating that it's working and waiting for communication with the PC and Bathy-2010 PC Software.

8.2 Firmware Update

The Bathy-2010 Sensor is a self-contained unit and has it's own set of Firmware. Periodically, SyQwest may offer Sensor Firmware upgrades which add new features and functionality. This section describes the process involved in updating that firmware.

Operations and Maintenance Manual

8.3 Firmware Update Connection

The Bathy-2010 Sensor Firmware requires a user supplied 9 pin D to 9 pin D serial data cable to be connected from the B2010 Server PC to the Sensor (J6). The Sensor is typically connected to the COM1 port on the Server.

8.4 Firmware Update Process

Get the latest version of the Bathy-2010 Firmware from SyQwest and copy the file onto the appropriate memory device so it can be accessed by the Bathy-2010 Server. The format for the file should be as follows: B2010P_V66S5.hex. The Firmware Version Number is the “66” and the “S” indicates a Single Channel System (a “D” in this location is for Dual Channel Systems). Then perform the following step to update the Bathy-2010 Sensor Firmware.

1. Start up the current Bathy-2010 Host Application and go to the “Help” menu selection. Then select “About Bathy-2010P”. When the dialog box appears with the version information, write down the current Firmware Version number (i.e. 61, 62). The .hex file from step 1 above should have a higher number than the current Firmware Version number.
2. Exit the Bathy-2010 Host Application and cycle power on the Bathy-2010 Sensor Unit.
3. Connect a Serial Cable from J6 on the Bathy-2010 Sensor Unit to the COM1 port on the Server.
4. After the reboot is complete, find the DSP Firmware Flasher Application either on the Desktop or from the “All Programs” selection under Syqwest, Bathy-2010P. (Start>Programs>SyQwest>Bathy-2010P>Util)
5. When the DSP Firmware Flasher program is started, the Windows Host and the Sensor will communicate via the selected serial port. The communication is logged to the display and should look like the figure below.

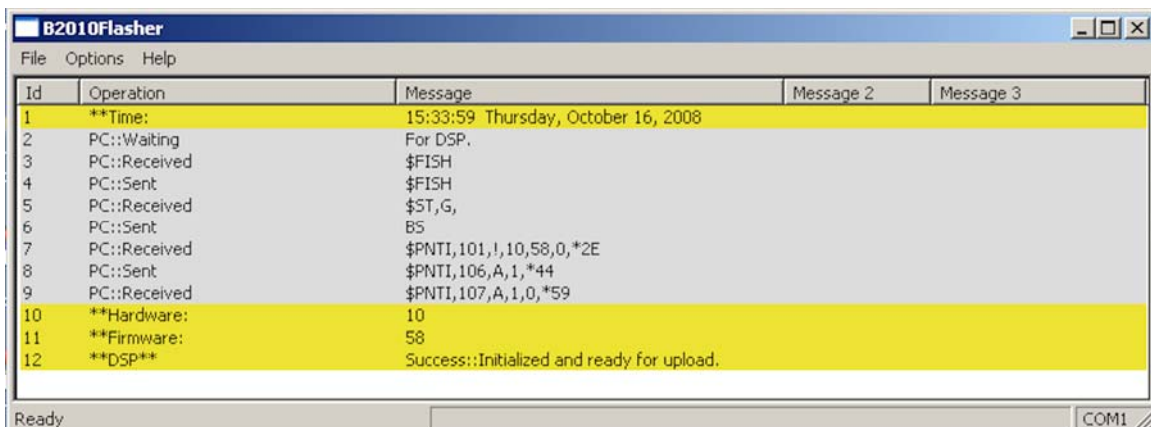

6. Once the communication has been established, select File, and Upload Firmware. You will be prompted to select a file so you will need to browse to the location where the (firmware) hex file from step 1 is located.
7. Select the file and hit OK. **Do not do anything with the Server or the sensor during the Firmware download sequence.** It will take about 2-5 minutes depending on the speed of your PC.
8. A message will appear when the update is complete. Sometimes it reports an error, *but it is always okay, ignore the error.*
9. Cycle power on the system and check the Firmware Version as described in step 2 above. The Firmware version number should reflect the number on the .hex file in step 1.
10. The Firmware update is complete.

8.5 Transducer Impedance Test

The transducer impedance may be tested previous to installation or after installation by using the following equipment and procedures.

Test equipment required:

- Dual channel oscilloscope.
- Signal generator, 10 VRMS, frequency range up to 200 khz
- Decade resistor box, 0-500 ohms in 1 ohm steps

Impedance measurement should be made under the following conditions to prevent damage:

- Transducer immersed under water
- Impedance of transducer should be predominantly resistive

Connect the transducer as per the Figure 8-1

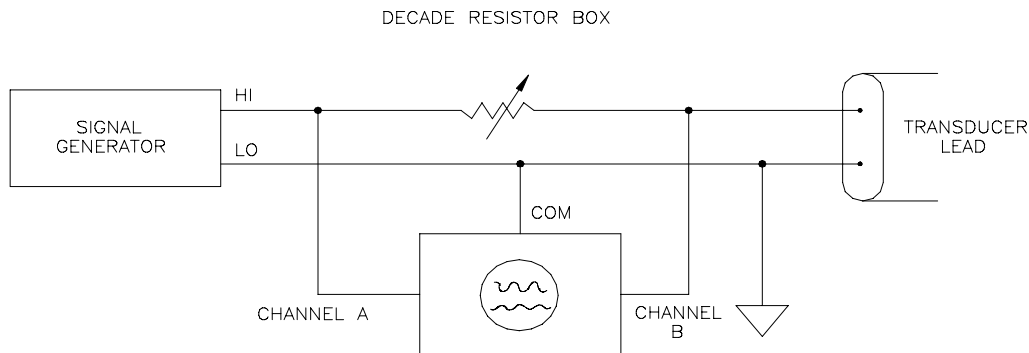

Figure 8-1 TRANSDUCER IMPEDANCE TEST DIAGRAM

**Operations
and
Maintenance Manual**

- Step 1** Set the signal generator for approximately 10 VRMS output at the center frequency of the transducer.
- Step 2** Measure the signal generator output with channel A.
- Step 3** Measure the voltage drop across the transducer with channel B.
- Step 4** Adjust the decade resistor box so that channel B is exactly one half of channel A.
- Step 5** Read the value of the decade resistor box. This value is the resistance of the transducer.

9.0 General Information

General Transducer

The Bathy-2010 is offered equipped with a single frequency or dual frequency transducer that is designed for portable, over-the-side mount applications. It may also be used in permanent installations. Before installing the transducer, the installer should read and understand the appropriate section below to insure that all of the installation issues are considered.

9.1 Selecting a Location for the Transducer

The location of the transducer is very important for maintaining reliable bottom tracking and optimum performance of the equipment. Avoid installing transducers in locations where the transducer will be subjected to turbulent water, air bubbles, or vibration. The best clear water location on most vessels meeting these criteria is approximately 1/3 the length of the vessel, aft from the bow.

For many portable applications and some permanent applications it is not practical to mount the transducer in the forward section of the vessel. For these applications the transducer can be located in the aft third of the vessel; away from and forward of shafts and propellers, clear of hull openings, sea chests, outlets or protuberances. It is preferable to mount the transducer on the side of the hull where the propeller blades are normally moving downwards. The upward motion of the propeller can generate pressure waves, which push air bubbles up against the hull. By mounting the transducer on the downward side, the hull will tend to protect the transducer from this effect.

The transducer should be mounted adjacent to the ship's centerline. The radiating face should be flush with the hull and, wherever practical, the face should be parallel to the waterline. A maximum deadrise angle of 3 degrees is allowable.

The transducer must be mounted such that it will always remain submerged during operation. Thus, the depth of the transducer should take into account the location on the vessel and the worst case sea state conditions. Turbulent flow across the radiating face of the transducer and/or the presence of air bubbles will degrade system performance significantly as well and must be considered.

The area selected for mounting must provide sufficient space for access to the transducer and cable, and for routing cable and conduit. In addition, there should be sufficient room to permit use of the necessary tools to facilitate the installation-mounting requirements. Ideally, the location would provide a relatively direct cable run to the site of the Bathy-2010 Sensor Unit.

Operations and Maintenance Manual

The cable path from the Electronics to the transducer should be routed as far as possible from other electrical cables. Although the cable is shielded, the acoustic reply from the transducer can be on the order of microvolts, thus any cable crosstalk emissions can cause a decrease in acoustic sensitivity.

9.2 Handling Transducers

The transducer is the heart of the Bathy-2010 system and, in spite of its appearance and size, is a delicate instrument. Although it is designed to be in contact with and survive tough marine environments, it should not be dropped or mishandled during the installation. Caution is advised when handling the transducer to prevent any damage to the transducer face or radiating surface.

The transducer and mounting assembly should be as clean and smooth as possible so the path of the sounding energy is uninterrupted. The transducer face must not be painted with lead based bottom paint. In portable applications the transducer and mounting assembly should be cleaned with fresh water after use.

WARNING: Do not expose the transducer to any solvents when cleaning any excess sealants. Strong solvents may damage the face of the transducer.

Also, when handling the transducer, avoid lifting or pulling on the transducer cable. Although the cable appears thick and substantial, the internal cable wiring could be damaged by stress from the sheer weight of the transducer and cause a malfunction at the most inopportune time.

9.3 Portable Transducer Installation

Portable installations of the Bathy-2010 transducer for most survey vessels will be of the over-the-side pipe mount type. This type of installation is achieved with items listed, or similar to the following list of materials: (* denotes optional items, not supplied with standard system)

Part Number	Item	Quantity
* 973690	Transducer , TR109 , 3.5Khz 10 deg	2-4
* P03051-X	Over the Side Mount (OTSM) Assembly (for TR109 above) (or can be user supplied pipe mount described below)	1 Kit
User Supplied	Silicone grease or petroleum jelly (Vaseline®)	1
User Supplied	Pipe coupling to attach to transducer	1
User Supplied	Pipe with threads to match the pipe coupling and length to give proper transducer depth	1
User Supplied	Pipe coupling adapter	1
User Supplied	Support Lines or cables (fore/aft)	2
User Supplied	Pipe Clamps to affix the Pipe to the 4x4	1 (or 2)
User Supplied	Pressure Treated 4x4x (Ship's Beam Width + 2 feet)	1

User Supplied	Large "C" Clamps to affix the 4x4 across the beam of the vessel	2
User Supplied	Protective Pads or Carpet Remnants	2
User Supplied	Mild Household Detergent (i.e.,dishwashing liquid)	1

Table 9-1 Portable Transducer Installation Parts

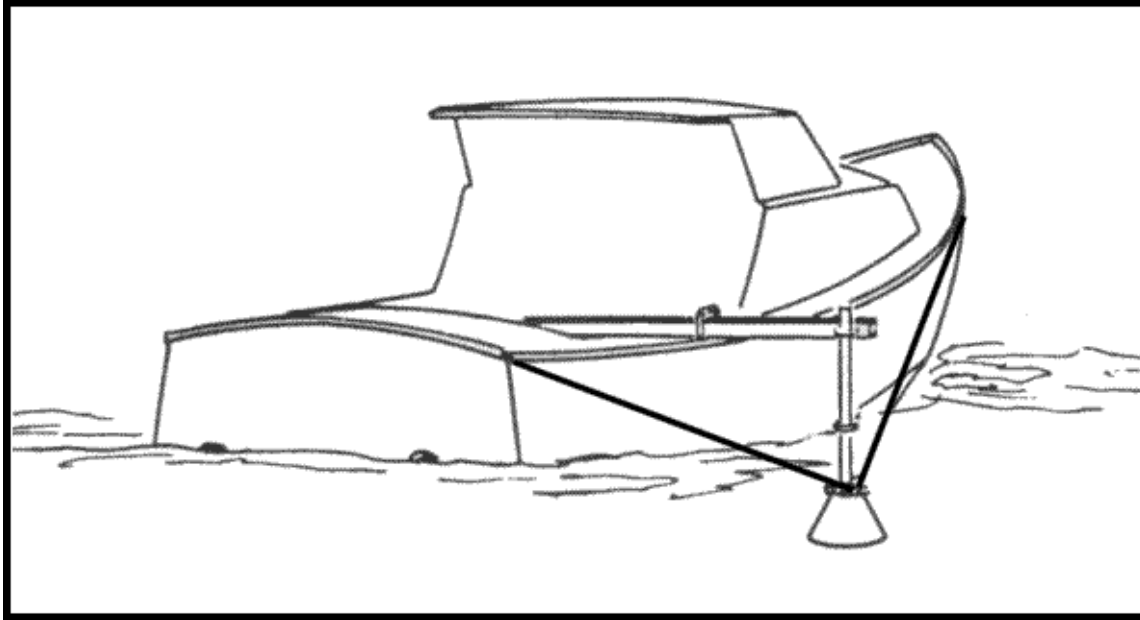

Figure 9-1 Typical Over the Side Mount (reference drawing)

Operations and Maintenance Manual

Refer to **Figure 9-1** above while reading and implementing the Installation procedure listed below.



Over The Side Transducer
Mounting
(Example mount shown as
reference only)

Figure 9-2 Over The Side Transducer Mounting Picture

CAUTION: Never pull, carry or hold the transducer by the cable as this may sever internal connections.

Typical Transducer Installation Procedure:

1. Apply silicone grease or petroleum jelly to the threads of the pipe to facilitate later disassembly.
DO NOT GET ANY GREASE ON THE TRANSDUCER FACE
2. Twist the pipe coupling onto the pipe.
3. Push the transducer cable through the pipe. Alternately after the transducer is attached, clamp the cable to the outside of the pipe using cable clamps.
4. Apply silicone grease or petroleum jelly to the transducer stem. Insure that the grease does not smear the face of the transducer.
5. Attach 2 lines or cables to the Transducer Mounting Assembly. These lines or cables will support the pipe from the force of the water when the boat is underway.
6. Attach the Pipe Clamp(s) near the end of the 4x4 insuring that there is enough clearance for the transducer to hang over the side of the vessel.
7. Place the 4x4 across the beam of the vessel near the stern and fasten it to the gunnels with the C Clamps. Use the Protective Pads or Carpet Remnants to protect the gunnels of the vessel. Insure that the 2 foot extra length of the 4x4 extends beyond the beam of the vessel on the appropriate side and that the Pipe Clamp(s) attached to the 4x4 are on the extra length as well.
8. Attach the Transducer/Pipe Assembly to the 4x4 using the Pipe Clamps. Insure that the transducer is deep enough into the water that sea conditions will not cause the transducer to get to the surface.
9. Fasten the line(s) or cable(s) fore and aft with sufficient tension to support the pipe when the boat is underway.

10. Route the cable to the instrument being careful not to tear the cable jacket. To reduce electrical interference, separate the transducer cable from other electrical wiring. Coil any excess cable and secure it in a place with zip-ties to prevent damage.

9.3.1 Portable Transducer Maintenance

Aquatic growth can accumulate rapidly on the transducer's surface reducing its performance in weeks. Clean the surface, keeping it free of marine growth and petroleum residue, with a soft cloth and mild household detergent. Inspect the cable periodically for kinks, abrasions and cuts. Repair any damage using an approved waterproofing cable repair system. Inspect connections for indications of corrosion.

WARNING: NEVER USE SOLVENTS!

Certain cleaners, gasoline, paint, sealants and other products may contain strong solvents, such as acetone, which can attack many plastics dramatically reducing their strength. Clean surface of transducer with a mild detergent only.

9.4 Permanent Transducer Installation

For some applications it may be necessary and/or convenient to mount the Bathy-2010 Transducer permanently in the hull of the vessel. A Seachest Installation can be used, but is not required. Guidelines for performing a Seachest installation are described in the following sections.

9.5 Seachest Transducer Installation

Interior Seachest installations are best suited for solid fiberglass hulls to permit a minimum attenuation of acoustic reply signals. Hulls of other type material types may be considered but most other hull types will require that a Seachest design be built into the hull with an acoustic window across the face of the enclosure (i.e. a significant hole must be cut out of the hull).

Inside mounting to the hull does minimize drag to allow faster survey speeds, however, loss of performance may result due to the attenuation loss in the hull.

Locate the transducer where the hull is solid fiberglass resin to maximize sound transmission. Do not locate over balsa wood core material. Consult the hull manufacturer if you are unsure of the core material or the best location. Never bond large resin housings directly to the hull; always use a liquid-filled box.

In any permanent installation the intended final configuration should be tested before it is implemented, if possible.

For more information regarding the installation of a Seachest or other permanent transducer mount, refer to our website at <http://www.syqwestinc.com>, or contact us directly.

THIS PAGE INTENTIONALLY LEFT BLANK

10.0 APPENDIX A Drawings and Parts Lists (BATHY 2010 SERVER Unit)

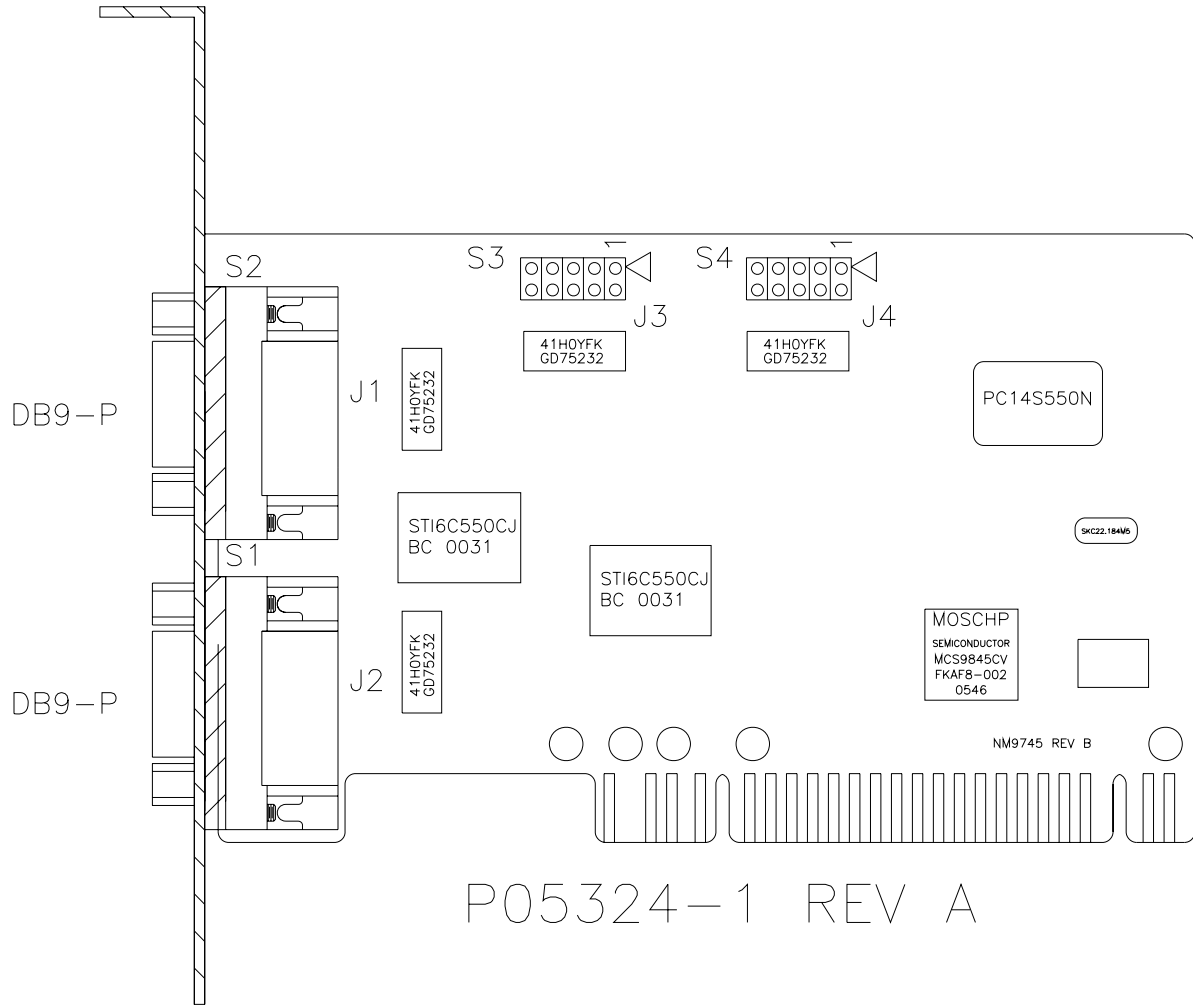

Figure 10-1 SERIAL I/O PCB

INTERFACE 4 CHANNEL SERIAL I/O PCB
P/N P05324

<u>FIND #</u>	<u>PART #</u>	<u>FSCM</u>	<u>DESCRIPTION</u>
1	P05324	33642	Interface 4 Channel Ser I/O PCB

THIS PAGE INTENTIONALLY LEFT BLANK

11.0 APPENDIX B Drawings and Parts Lists (BATHY 2010 SONAR Unit)

This section contains detailed Assembly drawings and Parts lists for the BATHY 2010 unit. It is helpful for referencing printed circuit boards and hardware locations

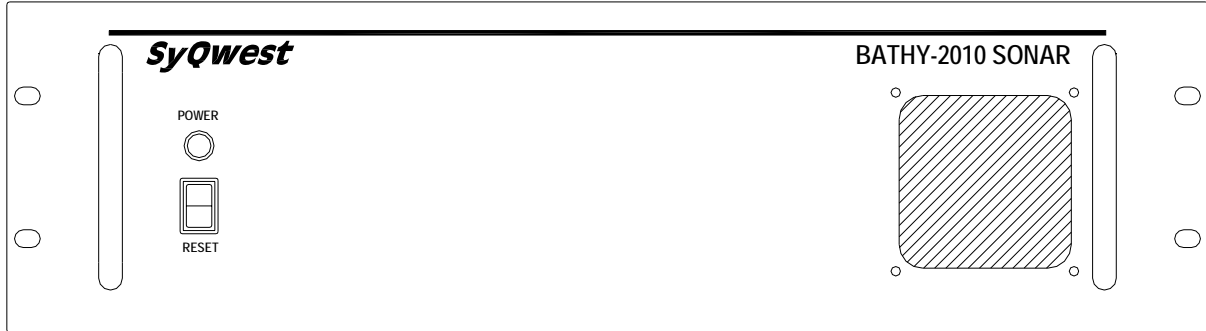

Figure 11-1 Sonar Unit Front Panel Indicators and Controls

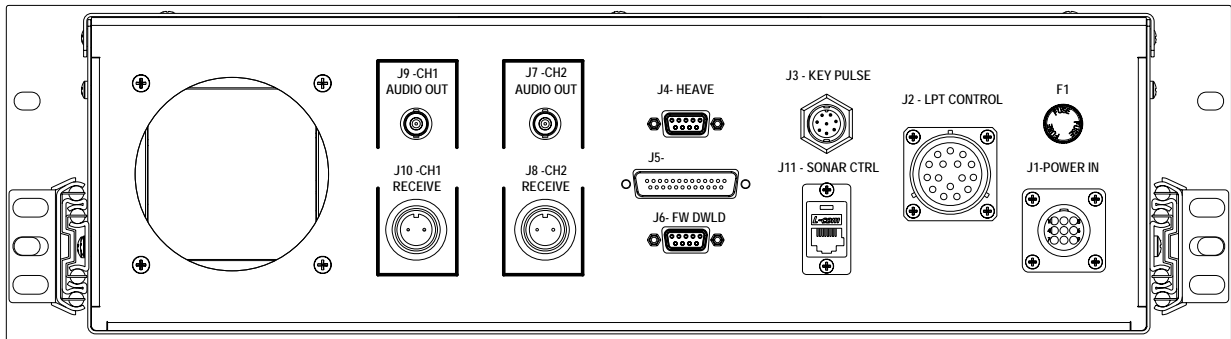

Figure 11-2 Sonar Unit Rear Panel Connections

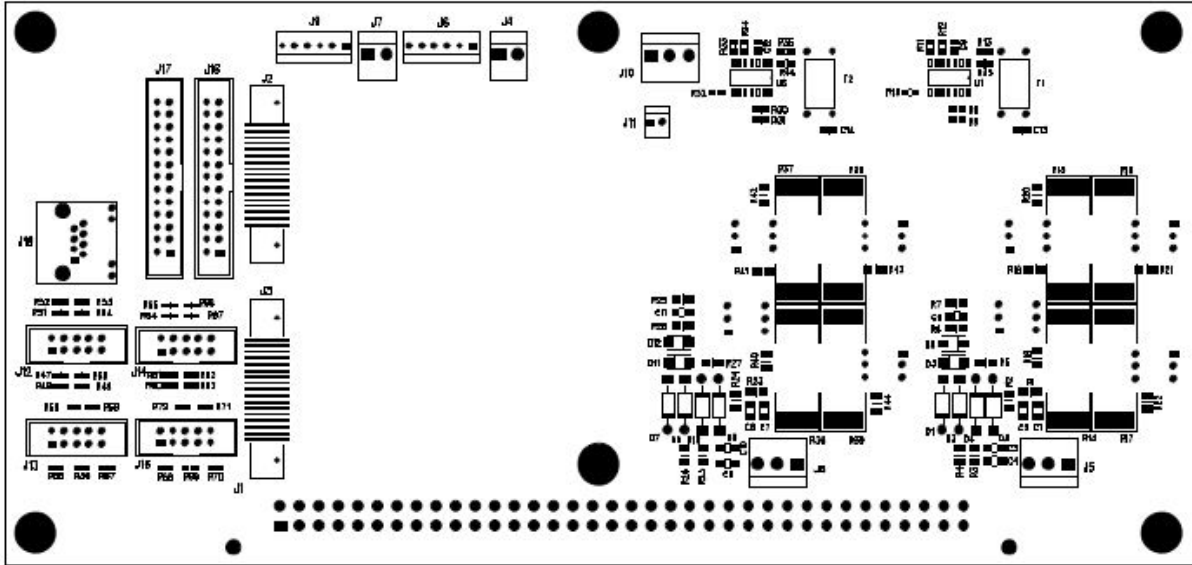
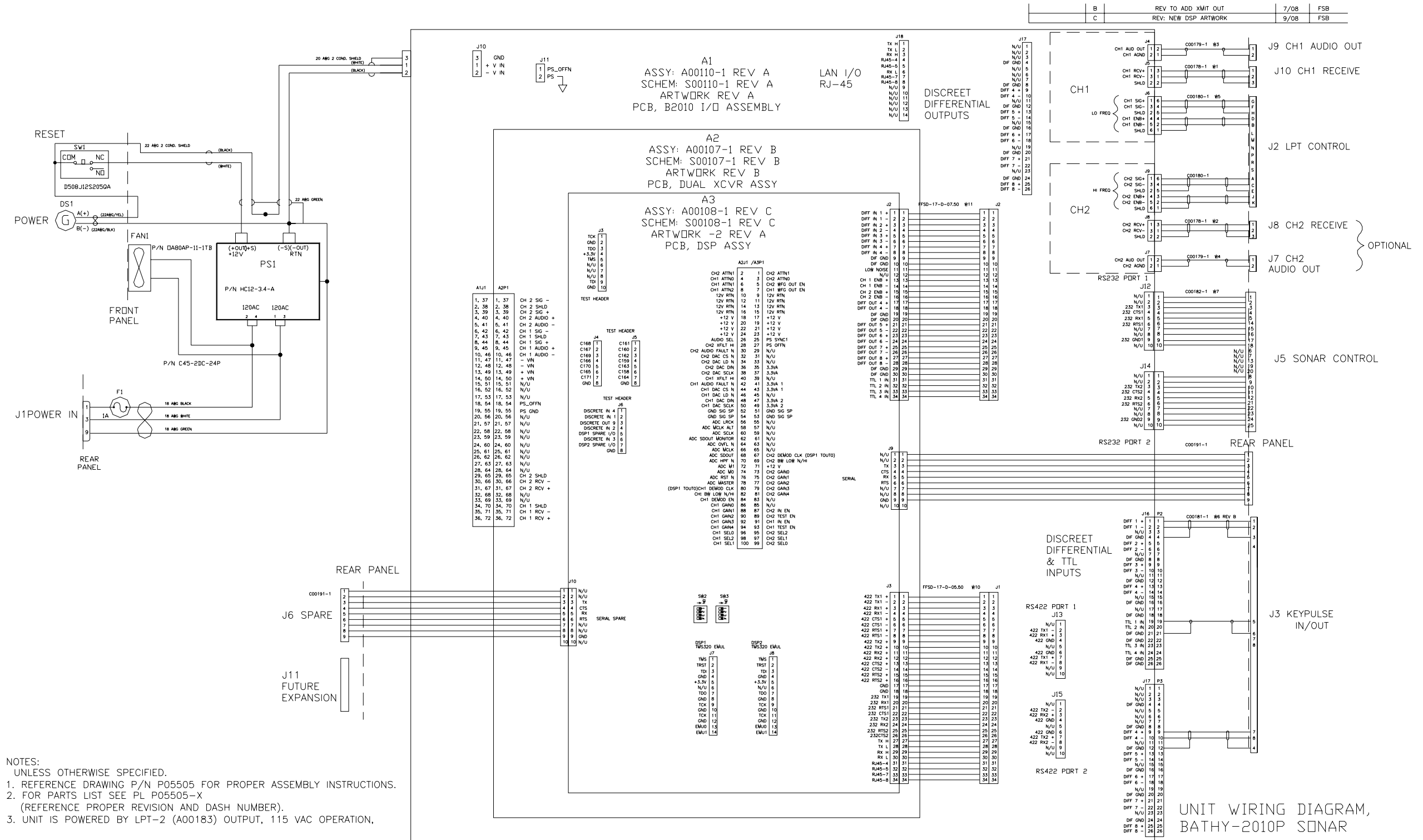

Figure 11-3 B2010 INTERFACE PCB
P/N A00110-1

<u>FIND #</u>	<u>PART #</u>	<u>FSCM</u>	<u>DESCRIPTION</u>
1	A00110-1	33642	I/O PCB



Sonar Unit Wiring Figure 11-4

THIS PAGE INTENTIONALLY LEFT BLANK

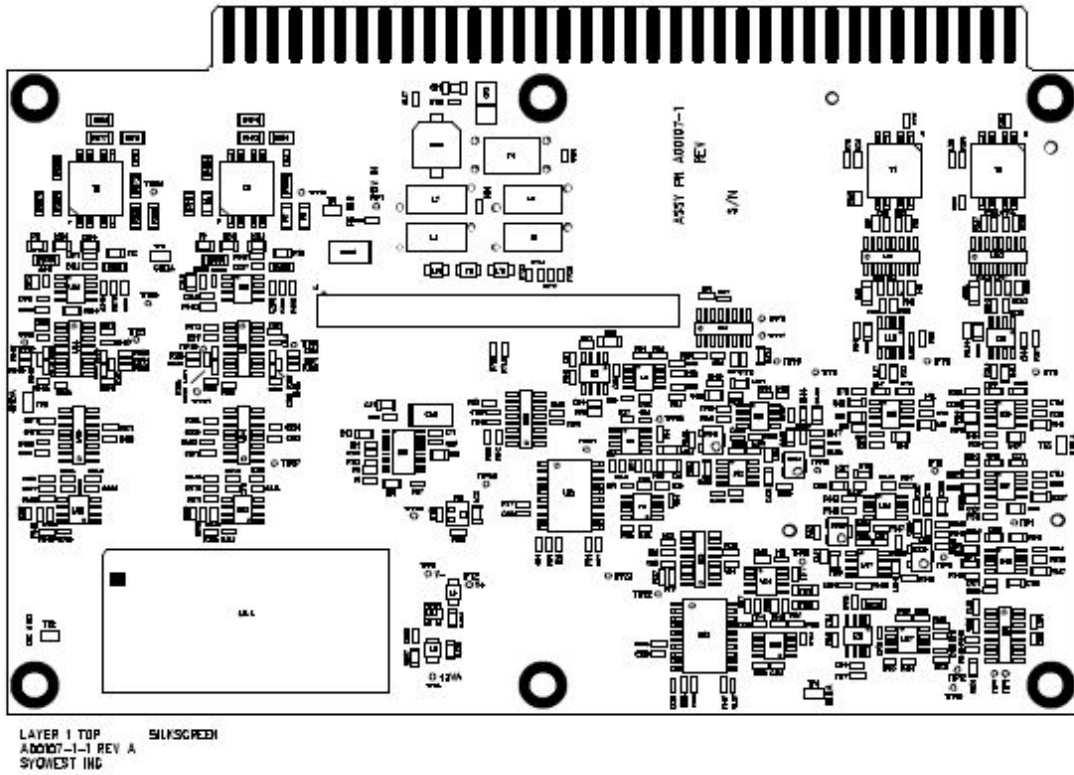

Figure 11-5 TRANSCEIVER PCB

APPENDIX B 11-1
TRANSCEIVER PCB
P/N A00107-1

<u>FIND #</u>	<u>PART #</u>	<u>FSCM</u>	<u>DESCRIPTION</u>
1	A00107-x	33642	Transceiver PCB

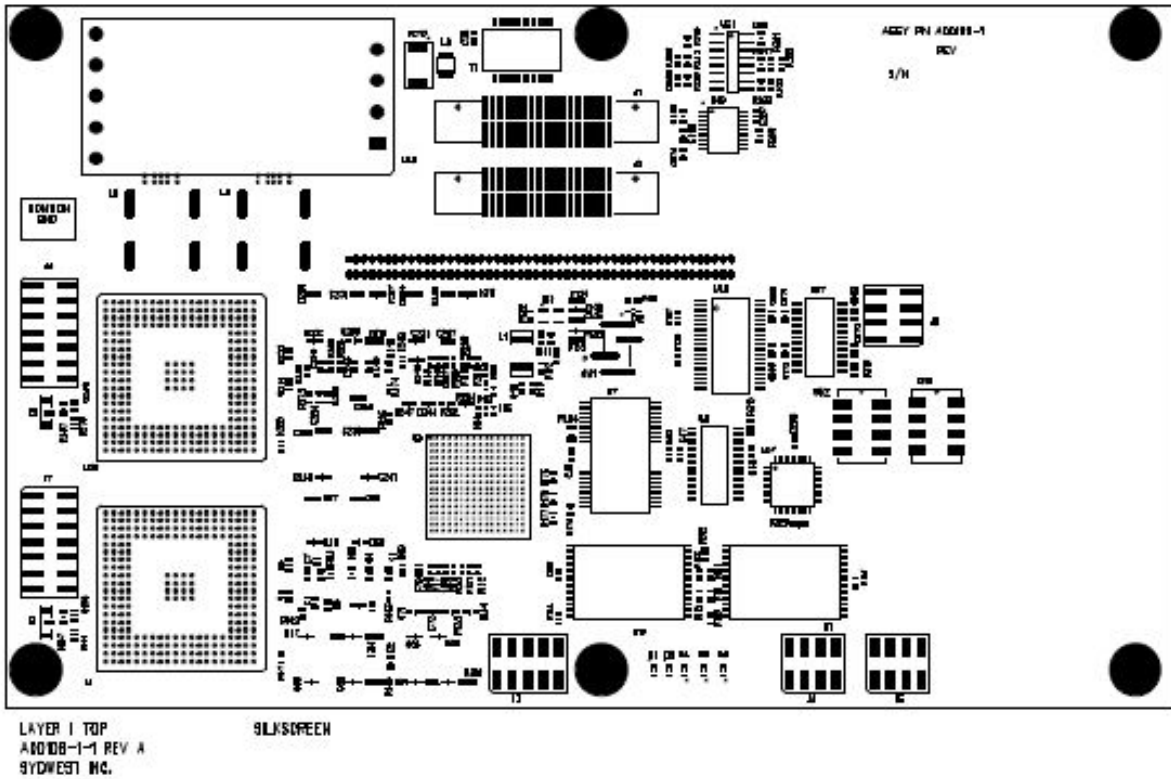

Figure 11-6 DIGITAL DSP PCB

APPENDIX B 11-2
DIGITAL DSP PCB
P/N A00108-1

<u>FIND #</u>	<u>PART #</u>	<u>FSCM</u>	<u>DESCRIPTION</u>
1	A00108 -x	33642	Digital DSP PCB

12.0 APPENDIX C Drawings and Parts Lists (LPT Unit)

This section contains detailed Assembly drawings and Parts lists for the BATHY 2010 unit. It is helpful for referencing printed circuit boards and hardware locations (Refer to Figures APPENDIX C - Figure 12-7 through APPENDIX C -Figure 12-12. For recommended spares to this unit refer to the table below.

PART NO.	DESCRIPTION	QTY.
P03340-1	LPA-5kVA Power Module Assembly	0
P03350-1	LPA-10kVA Power Module Assembly	1
P03350-2	LPA-5/5kVA Power Module Assembly	0
HA15-0.9A	Power Supply 16V	1
HtAA-16W-A	Power Supply +5V +/- 15V	1
A00046-2	Loss of Phase Detector PCB	1
A00048-x	Voltage & Current Monitor PCB	1
36DX352F450DJ2A	CAPACITOR 3500MF 450V SPRAGUE	1
36DX271F450AC2A	CAPACITOR 270uf 450 V.	1
120MB	Lamp	2
50748573332500	Green Led +5V	1
50748603332500	Green Led +14V	
326010	Fuse, 10A, Slo-Blo Ceramic	5
RH50-600-1%	Resistor	2
KAP5AG-120	Relay	1

Table 12-1

BASIC LPT-5 / 10 RECOMMENDED SPARES LIST

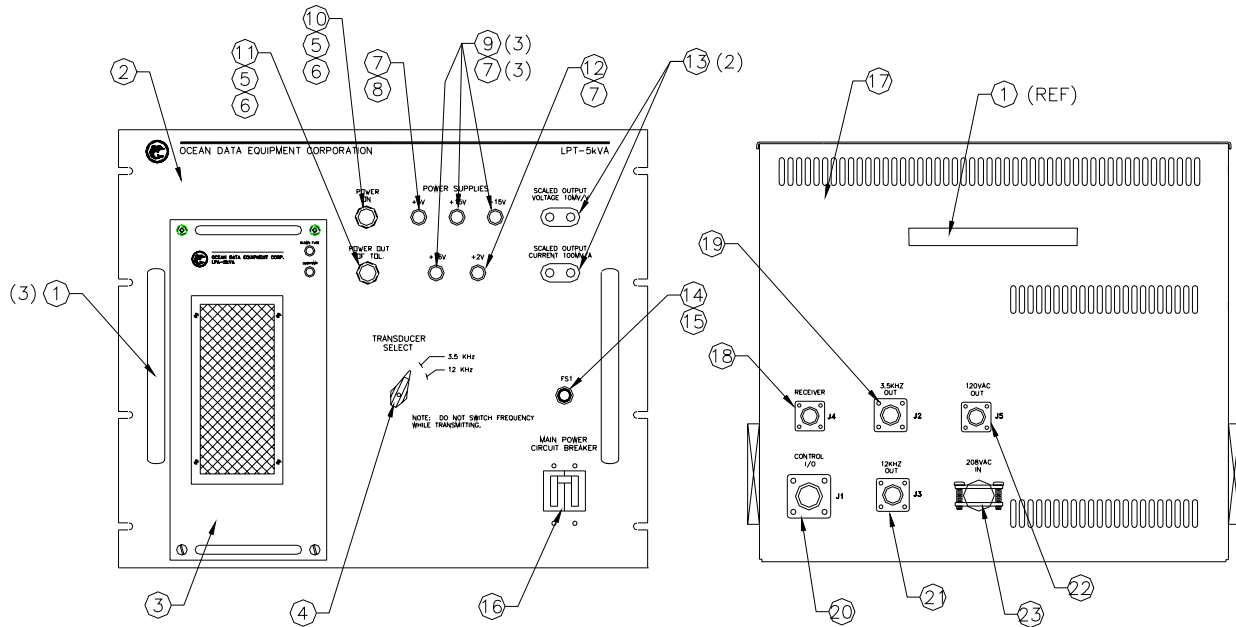

Figure 12-1 LPT-10 AMPLIFIER
LPT-5/ TOP LEVEL ASSEMBLY
P/N A000157-/A00171-

<u>FIND #</u>	<u>PART #</u>	<u>FCSM</u>	<u>DESCRIPTION</u>	<u>QTY.</u>
1	10963-SS-1032	06540	Handle	3
2	P00453-1	33642	Front Panel	1
3	P03350-1	33642	LPA-10kVA Power Module	1
4	A00070-1	33642	Current Sense Transformer PCB	2
5	31099	92966	Lamp Housing	1
6	120MB	92966	Lamp	1
7	508-8738-504	72619	Dialight Holder	5
8	50748563332500	72619	Green Dialight Led	1
9	50748603332500	72619	Green Dialight Led	3
10	30212	92966	Green Lens	1
11	30200	92966	Red Lens	1
12	50748573332500	72619	Green Dialight Led	1
13	01-1504-1-0300	18310	Dual Binding Post	2
14	313010	75915	Fuse	1
15	344125-A	75915	Fuse Holder	1
16	W92X11-2-40	77342	Circuit Breaker	1
17	P00612-1	33642	Rear Panel	1
18	PT02A-12-3S	33642	Connector	1
19	MS3102A-16-10S	96906	Connector	1
20	MS3102A-22-14S	96906	Connector	1
21	MS3102A-16-1S	96906	Connector	1
22	MS3102A-14S-7SN	96906	Connector	1
23	9747	28520	Connector Clamp	1
24	603-3	26405	Terminal Block	1

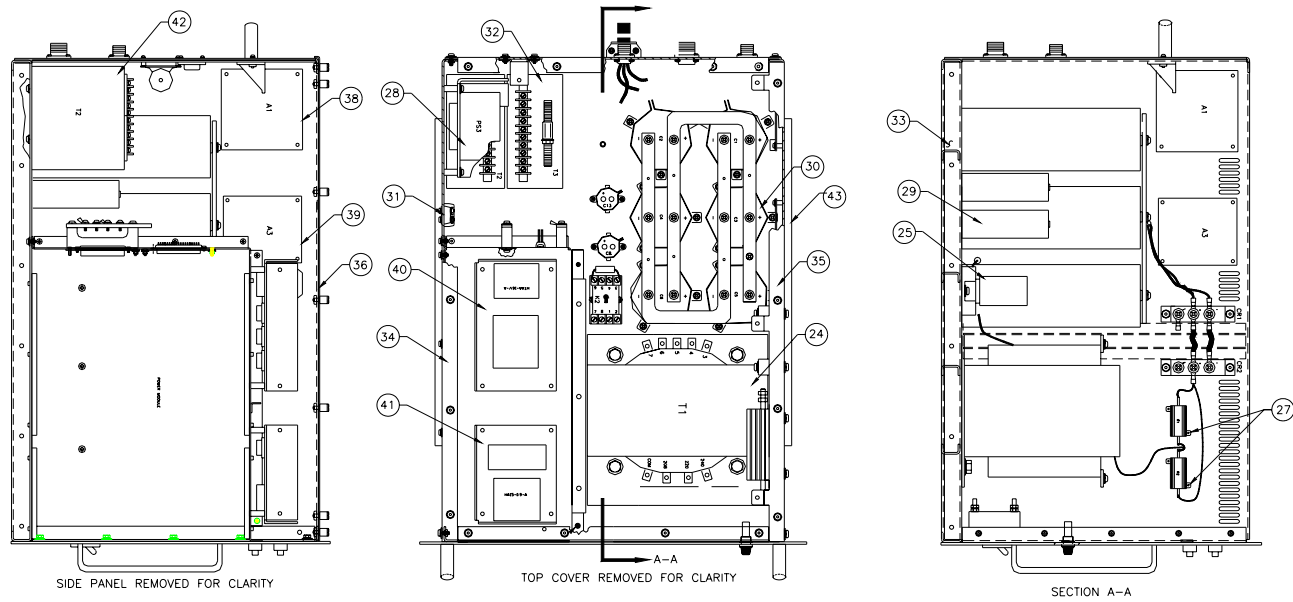

Figure 12-2
LPT-5/10P LEVEL ASSEMBLY
P/N A00057-X, A00171-X

<u>FIND #</u>	<u>PART #</u>	<u>FSCM</u>	<u>DESCRIPTION</u>	<u>QTY.</u>
24	P00330-1	33642	Single Phase Transformer	1
25	KAP5AG-120	77342	Relay	1
26	27E122	89265	Relay Socket	1
27	RH50-600	91637	Resistor	2
28	HC2-6-A	54407	Power Supply	1
29	430P104X9600	01884	Capacitor	2
30	36DX352F450DJ2A	56289	Capacitor	6
31	601-7	26405	Terminal Block	1
32	P00344-1 or P00933-1 SYS DEPENDANT	33642	Audio Output Transformer	1
33	P00611-1	33642	Chassis Base	1
34	P00613-1	33642	Left Side Panel	1
35	P00552-1	33642	Right Side Panel	1
36	P00554-1	33642	Top Cover	1
37	A00048-x SYS DEPENDANT	33642	Voltage & Current Monitor PCB	1
38				
39	A00046-2	33642	Loss of Phase Detector PCB	1
40	HTAA-16W-A	54407	Power Supply	1
41	HA15-0.9A	54407	Power Supply	1
42	P00344-1 SYS DEPENDANT	33642	Audio Output Transformer	1
43	CTHRS-124	33642	Slides	1(PR)

THIS PAGE INTENTIONALLY LEFT BLANK

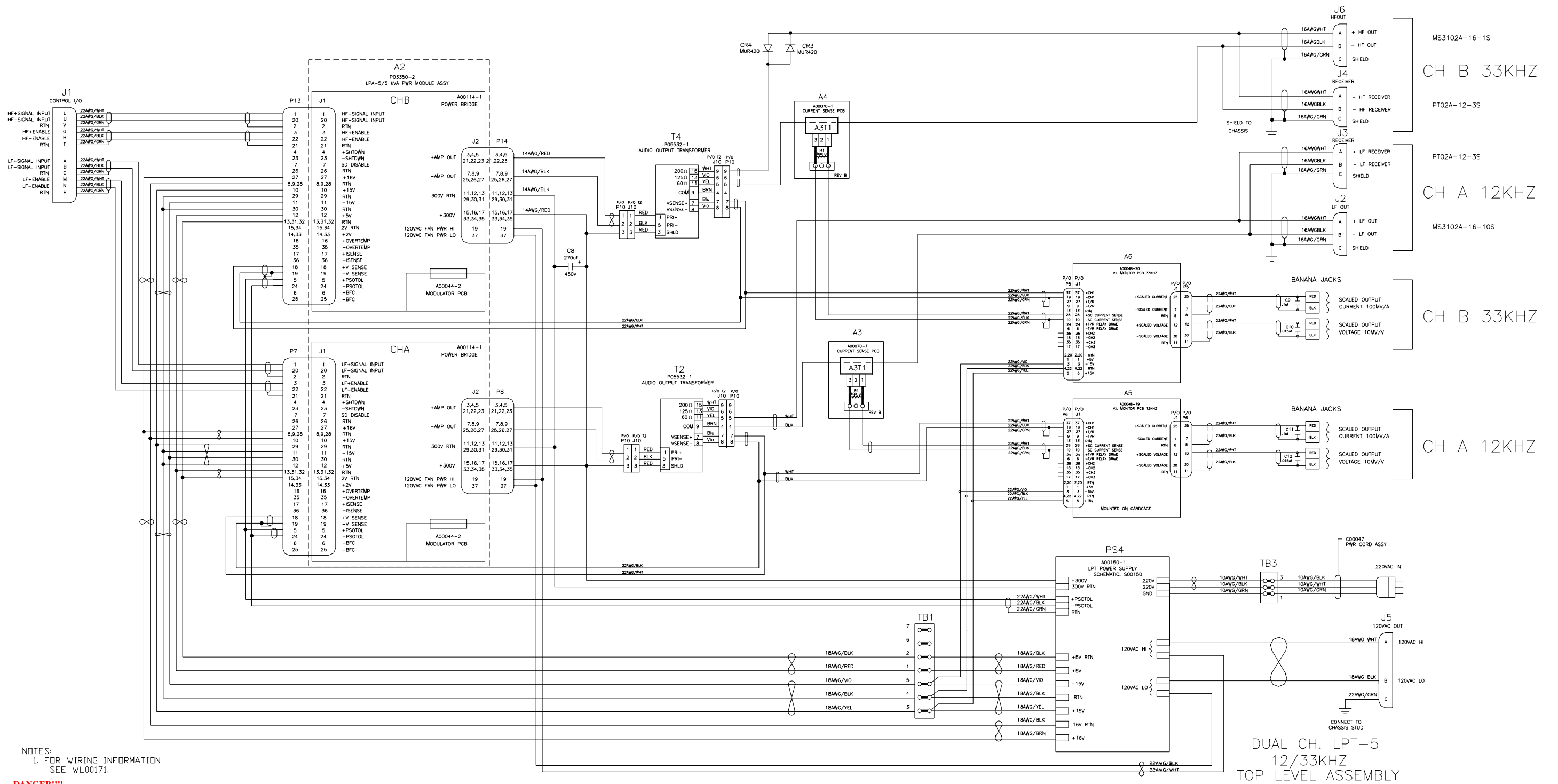

Figure APPENDIX C 10-5
LPT-5/5 UNIT WIRING DIAGRAM
P/N S000157-5

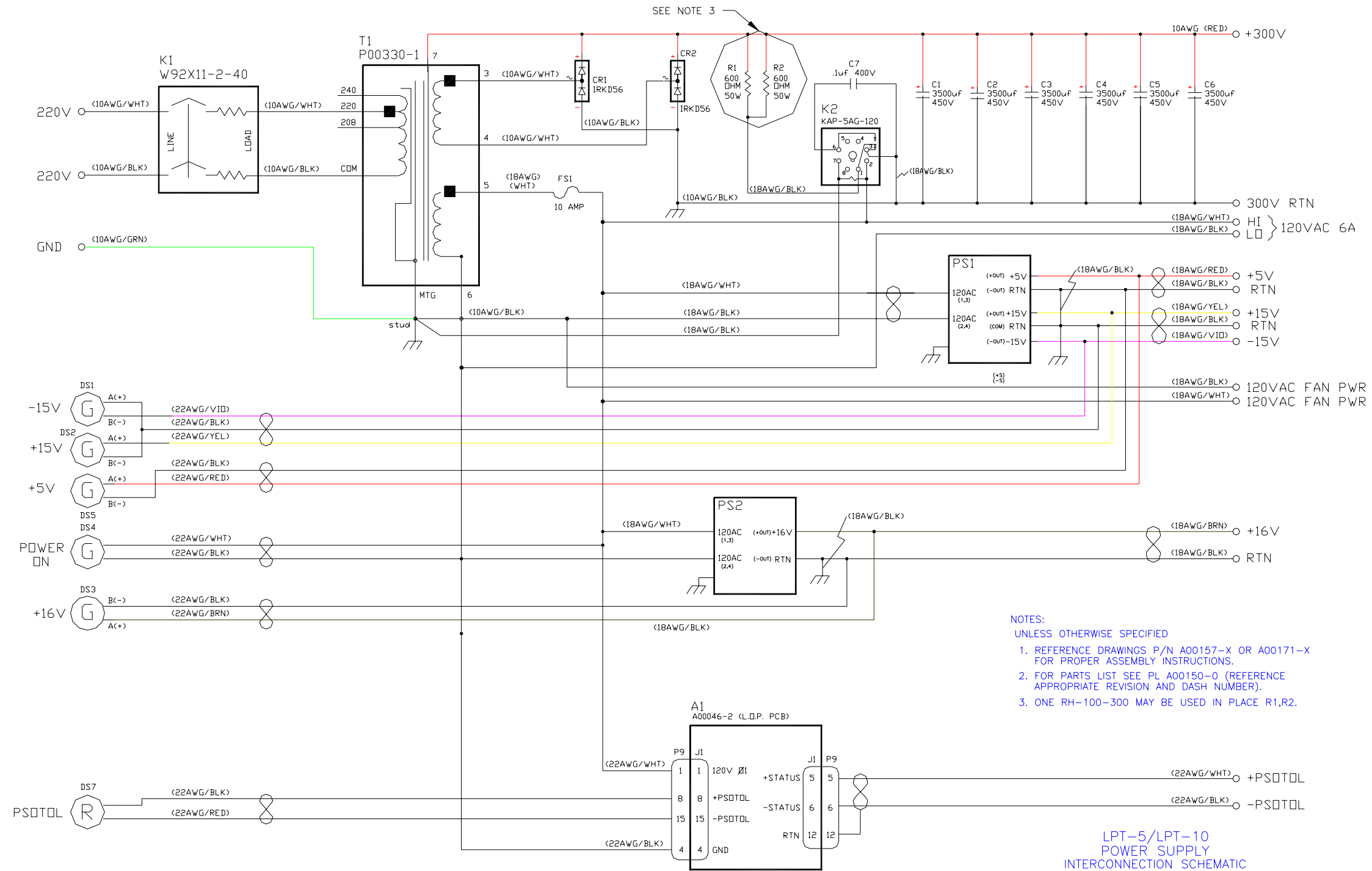
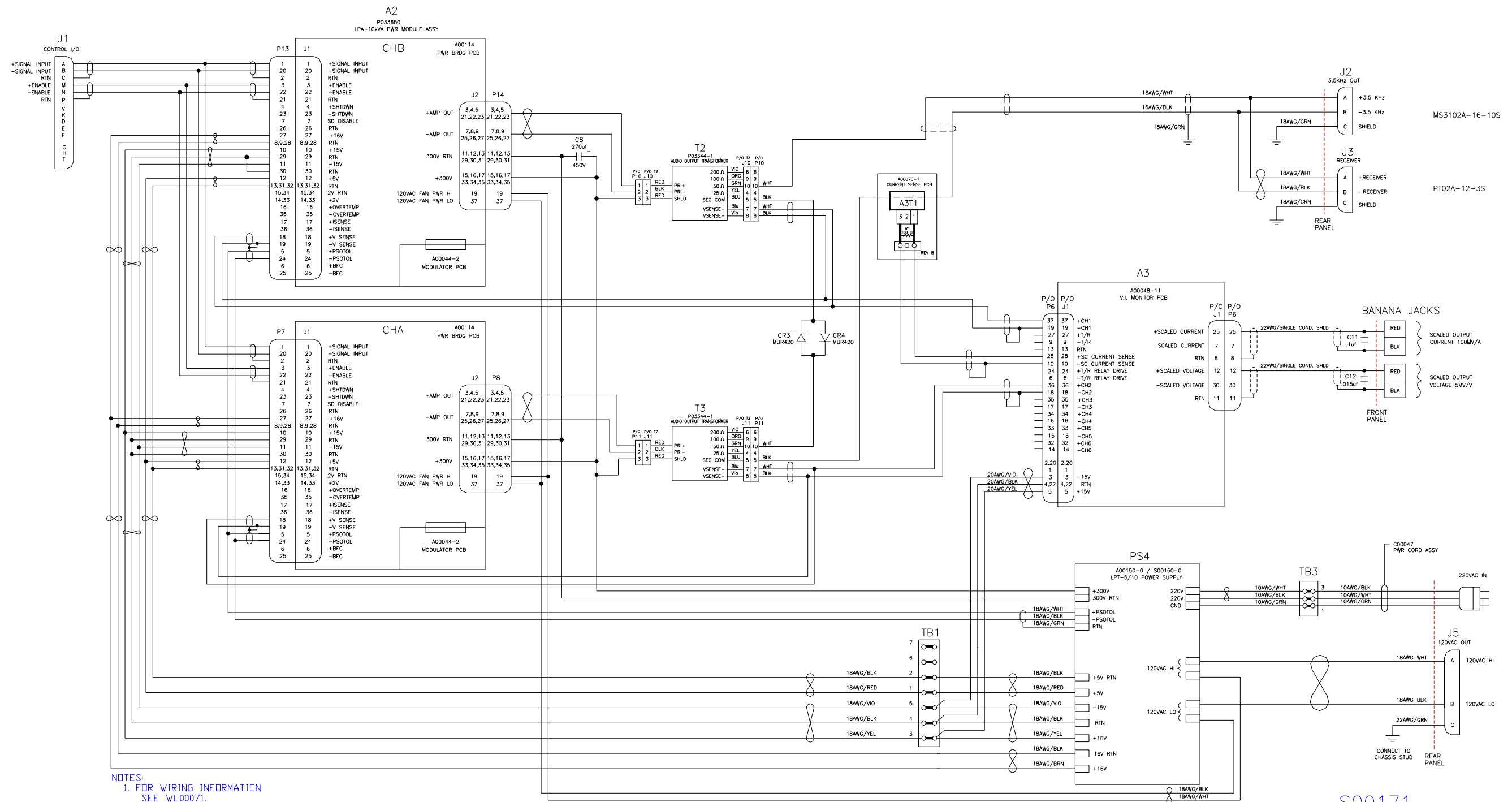

Figure APPENDIX C 10-6
LPT-5/10 POWER SUPPLY INTERCONNECTION SCHEMATIC
P/N S00150-0



NOTES:
1. FOR WIRING INFORMATION
SEE WL00071.

DANGER!!!!
HIGH VOLTAGES ARE PRESENT IN THE LPT!!

**ALWAYS DISCONNECT POWER, AND ALLOW TIME TO
DISCHARGE BEFORE OPENING COVER!**

S00171
LPT-10 UNIT
WIRING DIAGRAM

Figure APPENDIX C 10-6
LPT-10 UNIT WIRING DIAGRAM
P/N S000171-1

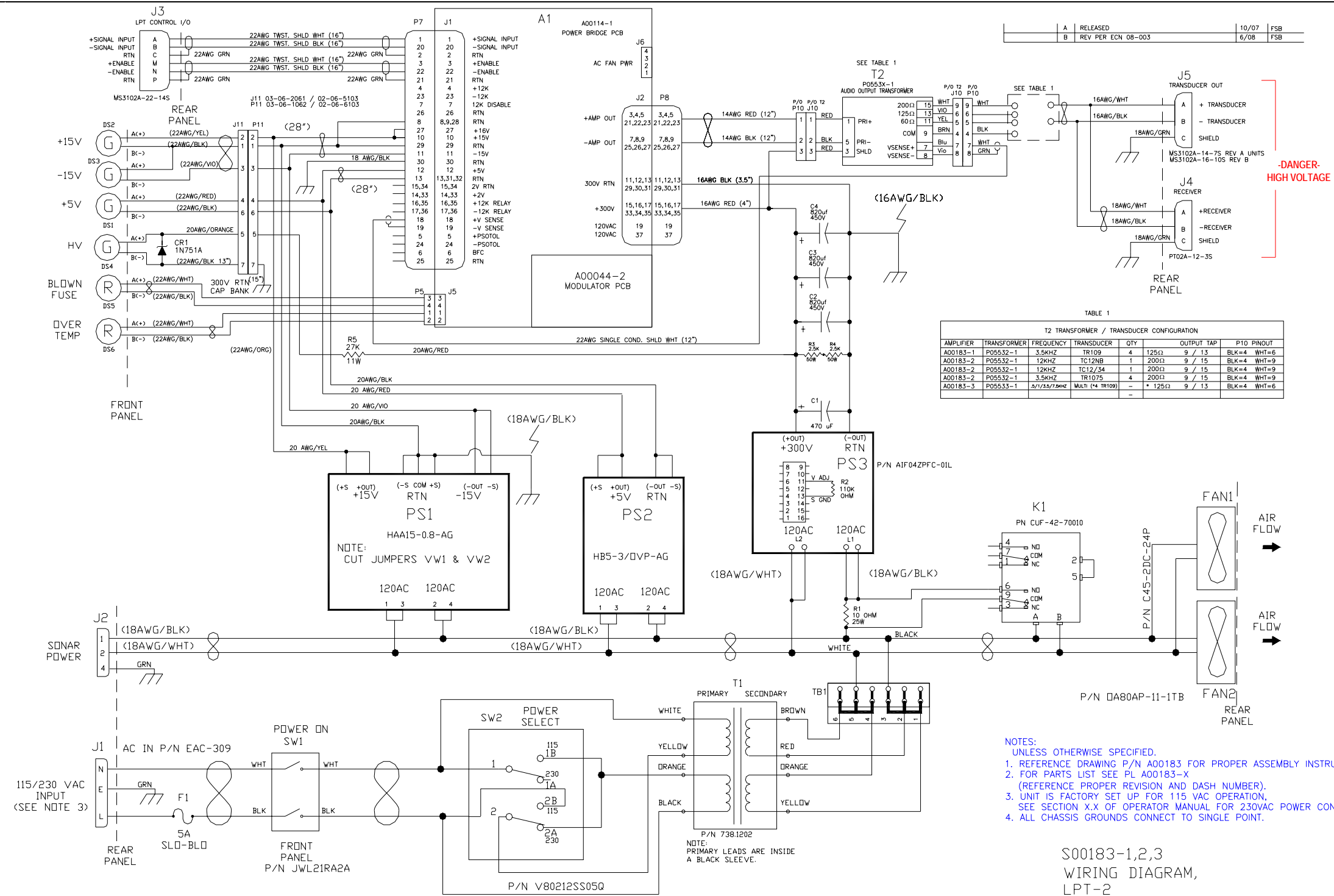

Figure 12-3
LPT-2/5P UNIT WIRING DIAGRAM
P/N S00183-X

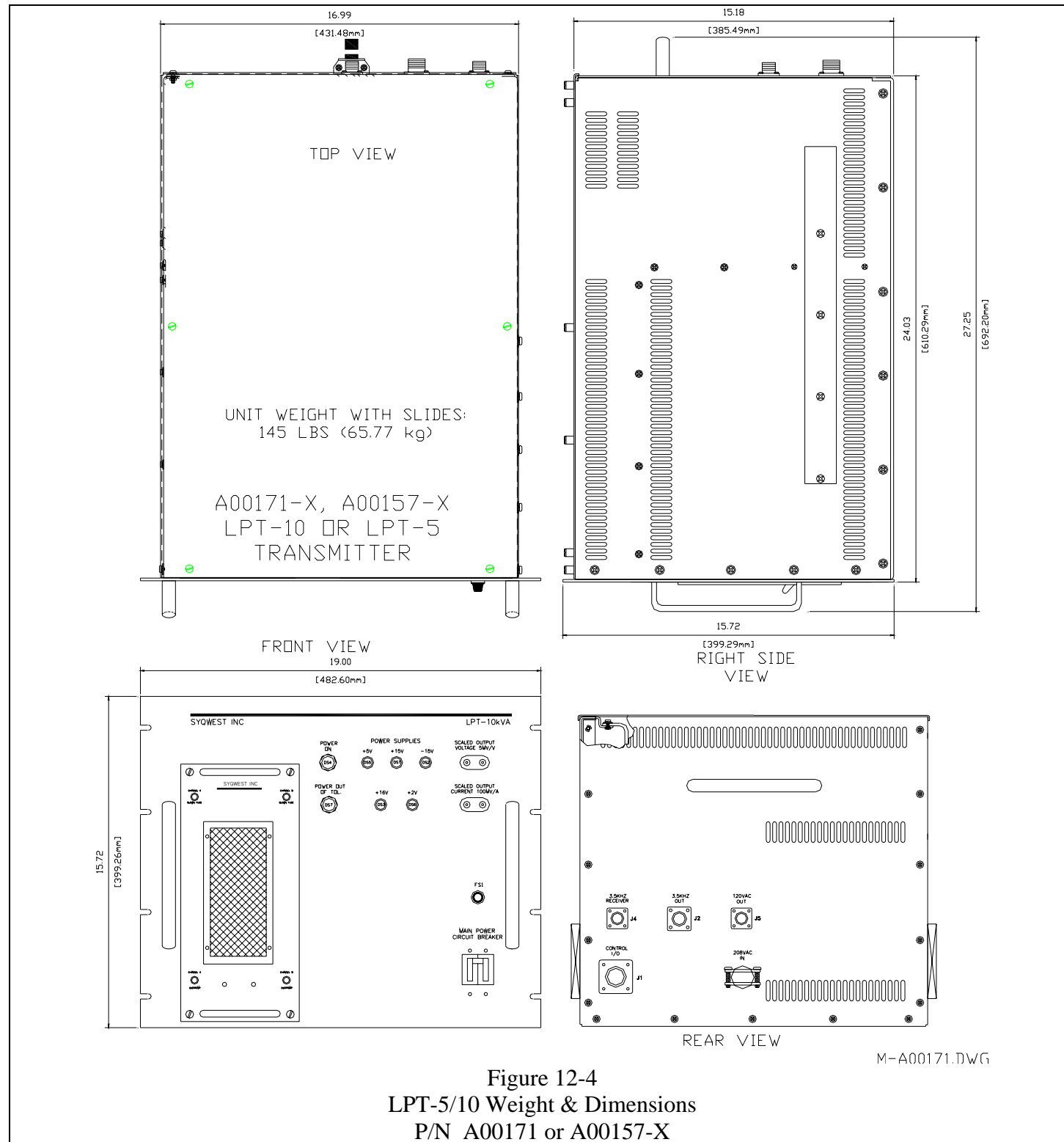

Figure 12-4
LPT-5/10 Weight & Dimensions
P/N A00171 or A00157-X

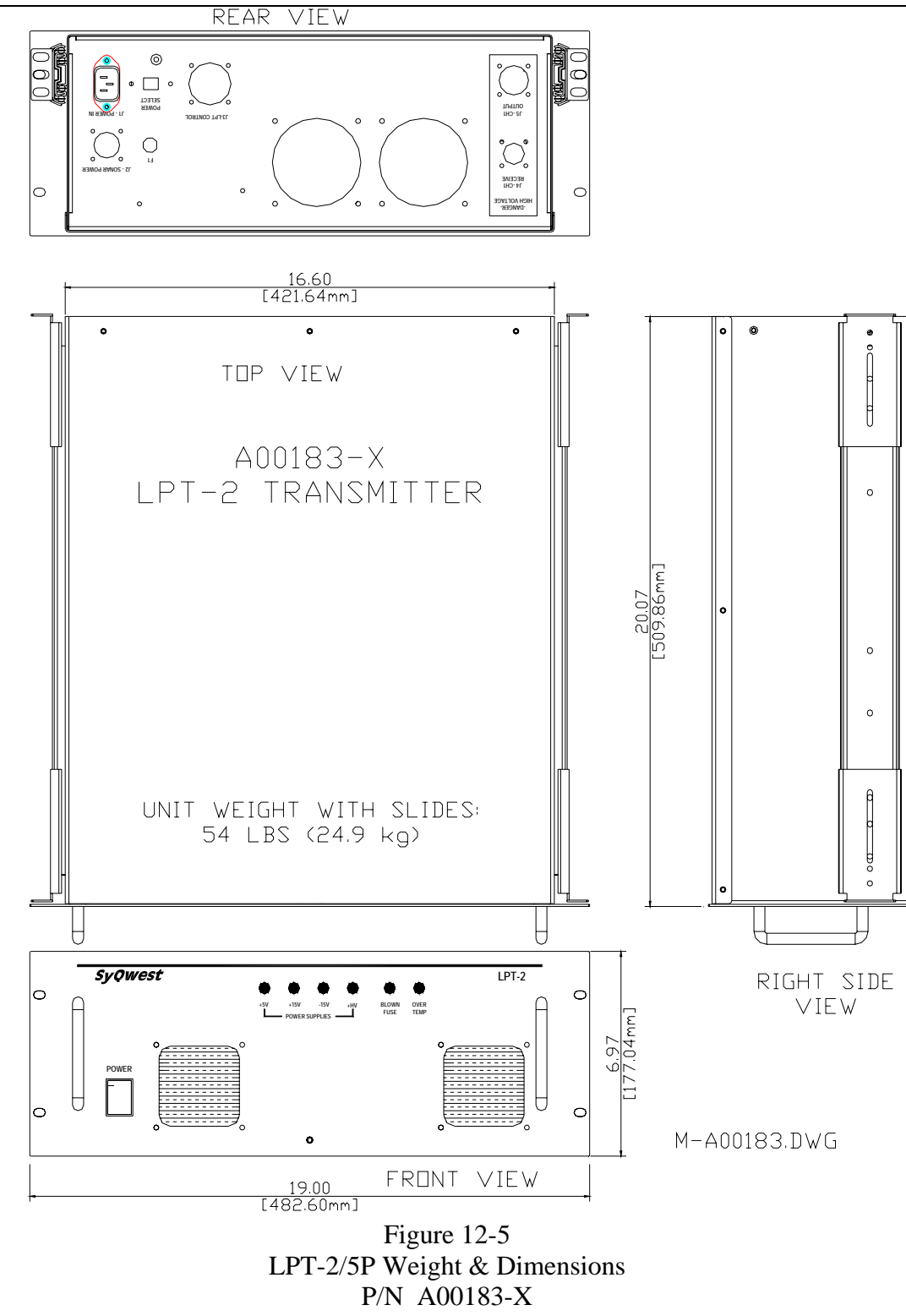

Figure 12-5
LPT-2/5P Weight & Dimensions
P/N A00183-X

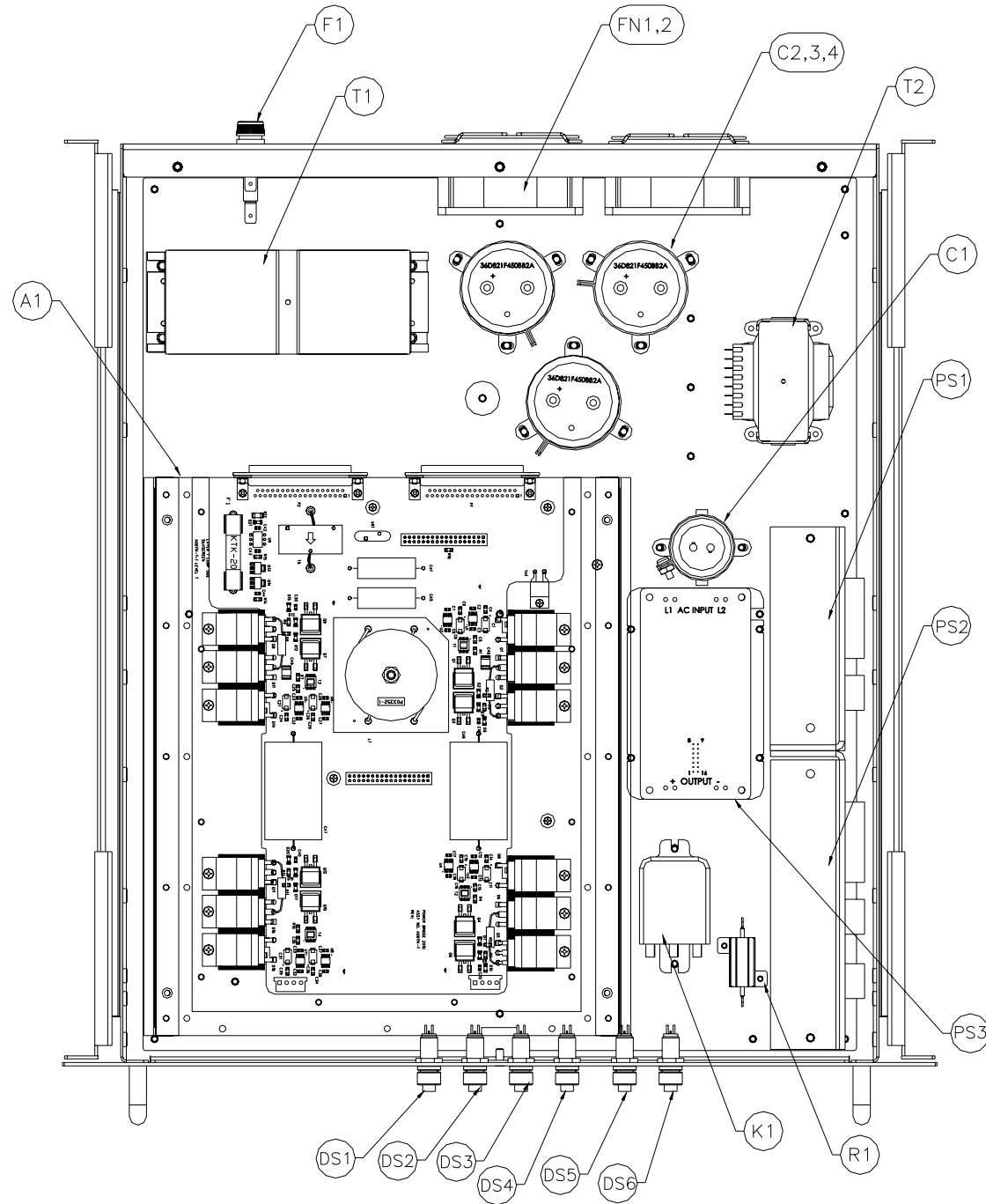

Figure 12-6
LPT-2 TOP LEVEL ASSEMBLY
P/N A00183-X

FIND #	PART #	DESCRIPTION	QTY.
A1	A00114-1	PCB,POWER BRIDGE DRIVER	1
A1A2	A00044-2	PCB, MODULATOR	1
C1	LPX471M450H9P3	CAPACITOR, 470UF, 450VDC	1
C2,3,4	36D821F450BB2A	CAPACITOR, 820UF, 450VDC	3
DS1,4	50748573332500	LED, GREEN +5V	2
DS2,3	50748603332500	LED, GREEN +14V	2
DS5,6	507-47573331500	LED, RED +5V	2
F1	313-005	FUSE, 5 AMP SLO BLO	1
FN1,2	OA80AP-11-1TB	FAN, 120VAC, 3100RMP	2
K1	CUF-42-70010	RELAY, TIME DELAY	1
PS1	HAA15-0.8-AG	POWER SUPPLY, ± 15VDC	1
PS2	HB5-3/OVP-AG	POWER SUPPLY, +5VDC	1
PS3	AIF04ZPFC-01L	POWER SUPPLY, 300V	1
R1	RH-25-10	RESISTOR, 10OHM, 25W	1
T1	738-1202	TRANSFORMER, TORROID	1
T2	P05532-1	AUDIO OUTPUT TRANSFORMER	1

Table 12-2 LPT-2 PARTS LIST
P/N A00183-X

THIS PAGE INTENTIONALLY LEFT BLANK

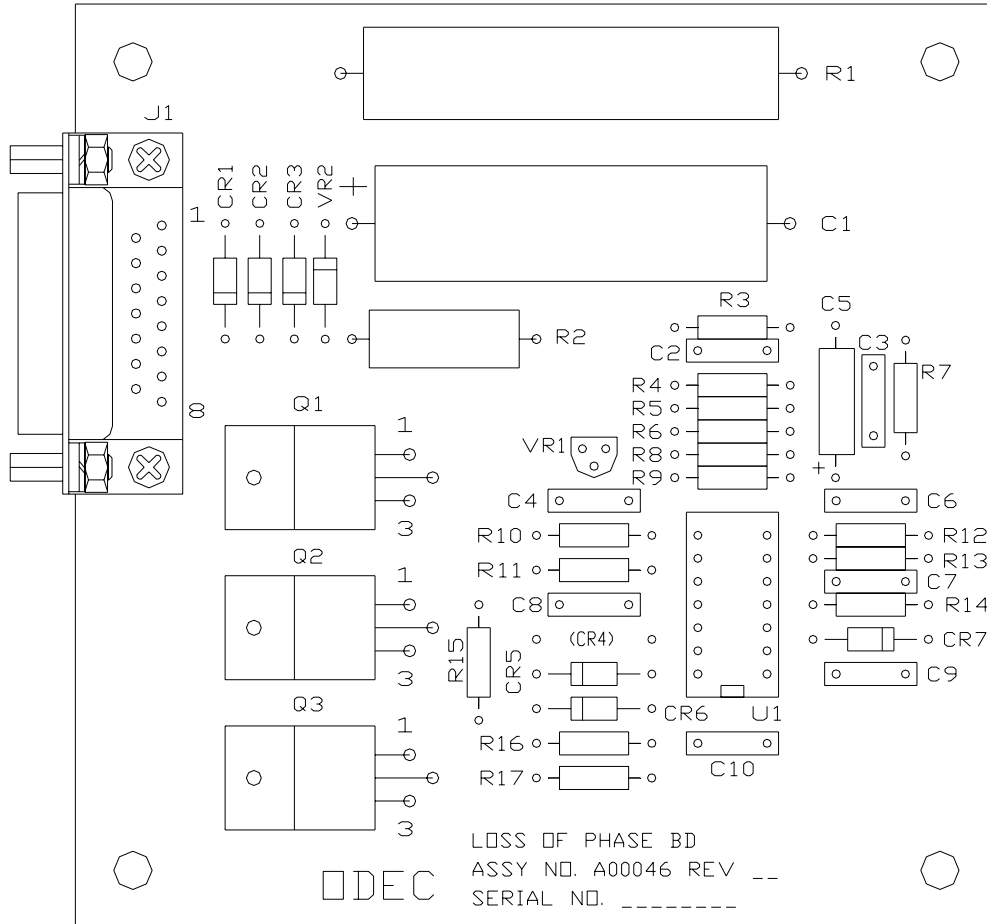

Figure 12-7
LOSS OF PHASE DETECTOR PCB
P/N A00046-2

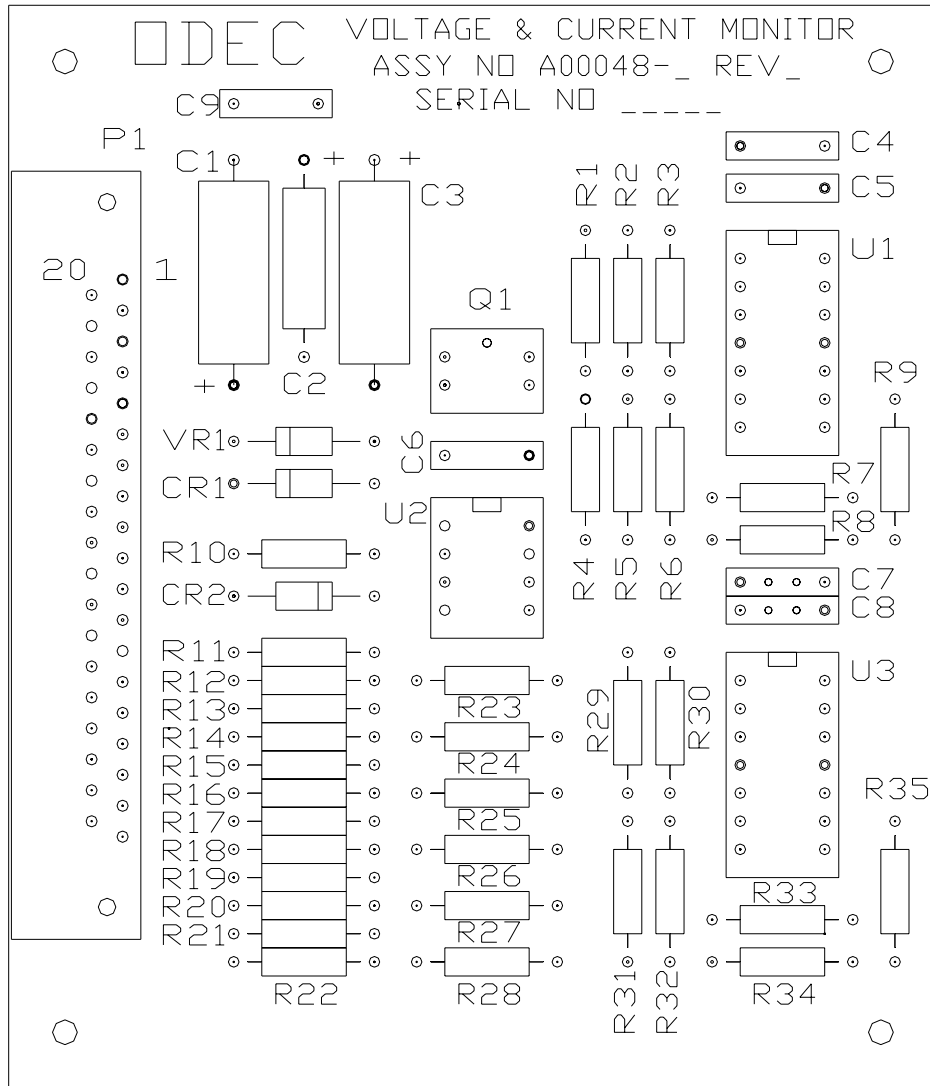

Figure 12-8
VOLTAGE & CURRENT MONITOR PCB
P/N A00048-x

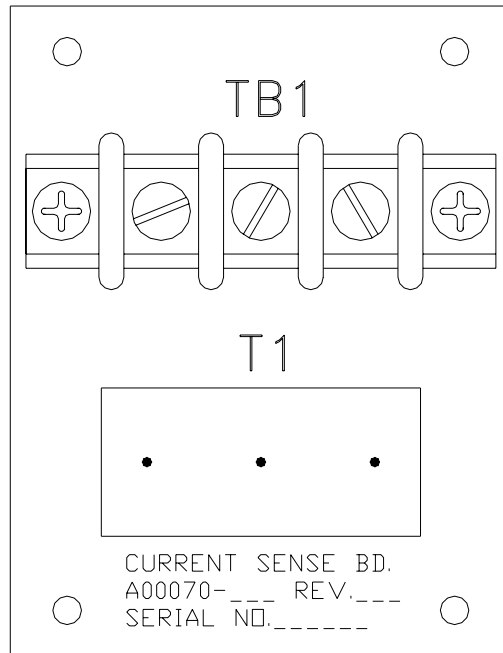

Figure 12-9 CURRENT SENSE PCB
P/N A00070-1

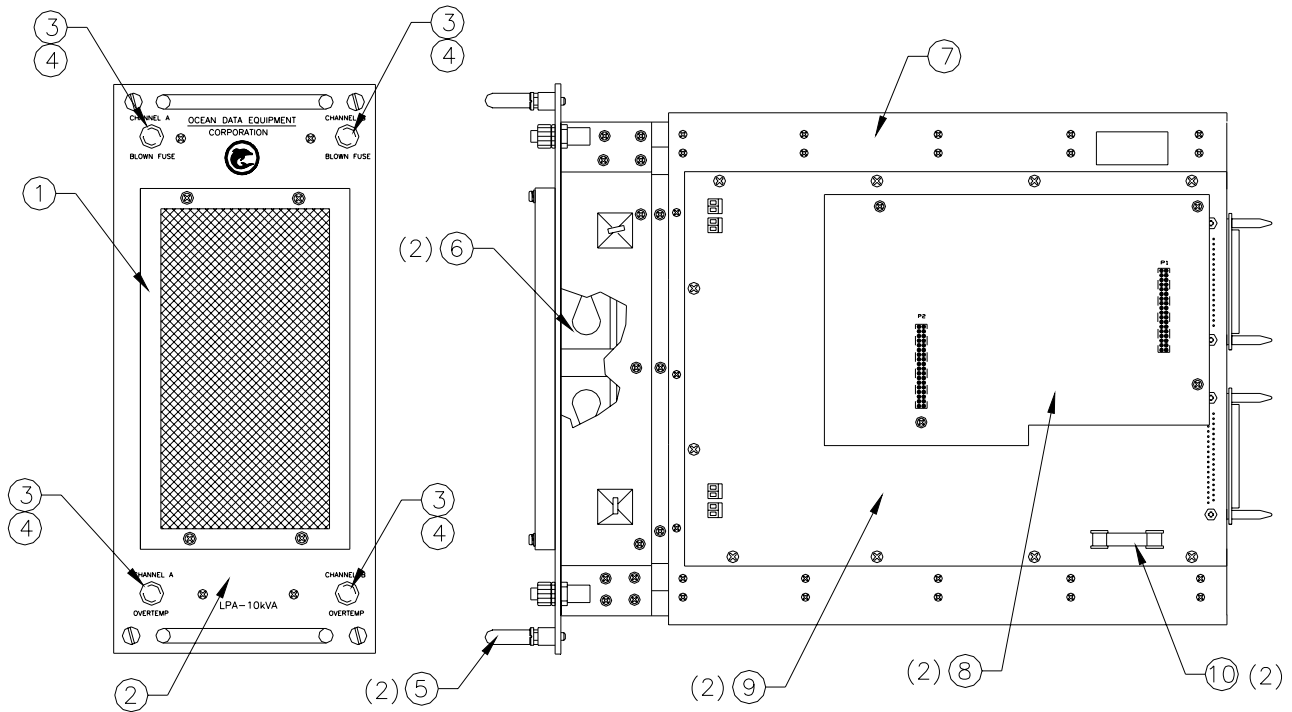

Figure 12-10 LPA- MODULE ASSEMBLY AND PARTS LIST
 P/N P03340-1 LPA 5
 P/N P03350-2 LPA 5/5
 P/N P03350-1 LPA 10

<u>FIND #</u>	<u>PART #</u>	<u>FSCM</u>	<u>DESCRIPTION</u>	<u>QTY.</u>
1	P00574-1	33642	Filter	1
2	P03320-1	33642	Front Panel	1
3	507-47573331500	72619	Led, Red	2 (4)
4	508-8738-504	72619	Led Holder	2 (4)
5	10376-SS-0832	06540	Handle	2
6	8506N	23936	Fan	2
7				
8	A00044-2	33642	Modulator PCB	1 (2)
9	A00114-1	33642	Power Bridge PCB	1 (2)
10	KTK - 20	33642	Fuse; 20AMPS, 600V	1 (2)2

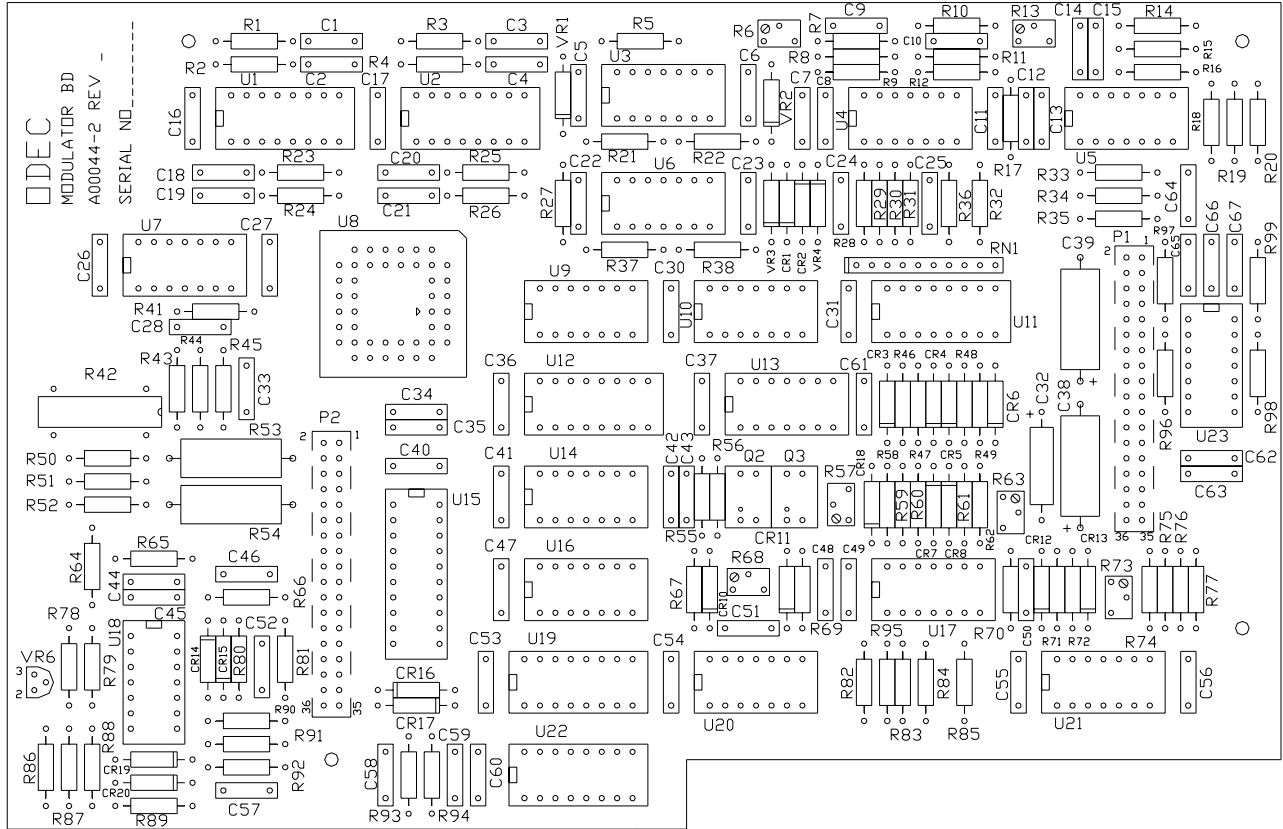

Figure 12-11 MODULATOR PCB
P/N A00044-2

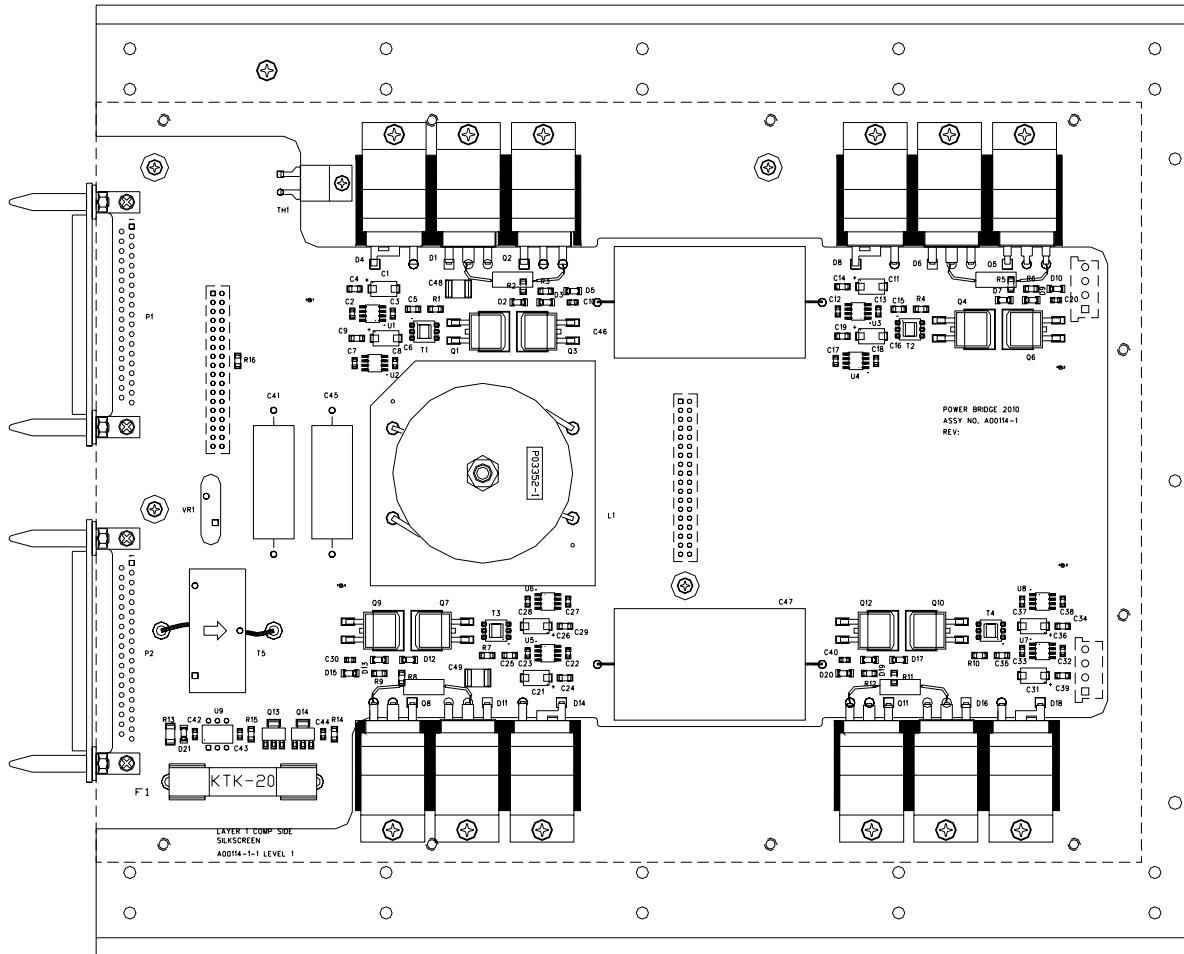

Figure 12-12 POWER BRIDGE PCB
P/N A00114-1

SYQWEST, INC.
<http://www.syqwestinc.com> tech-support@syqwestinc.com

END OF MANUAL